

FRESA INTERRASASSI

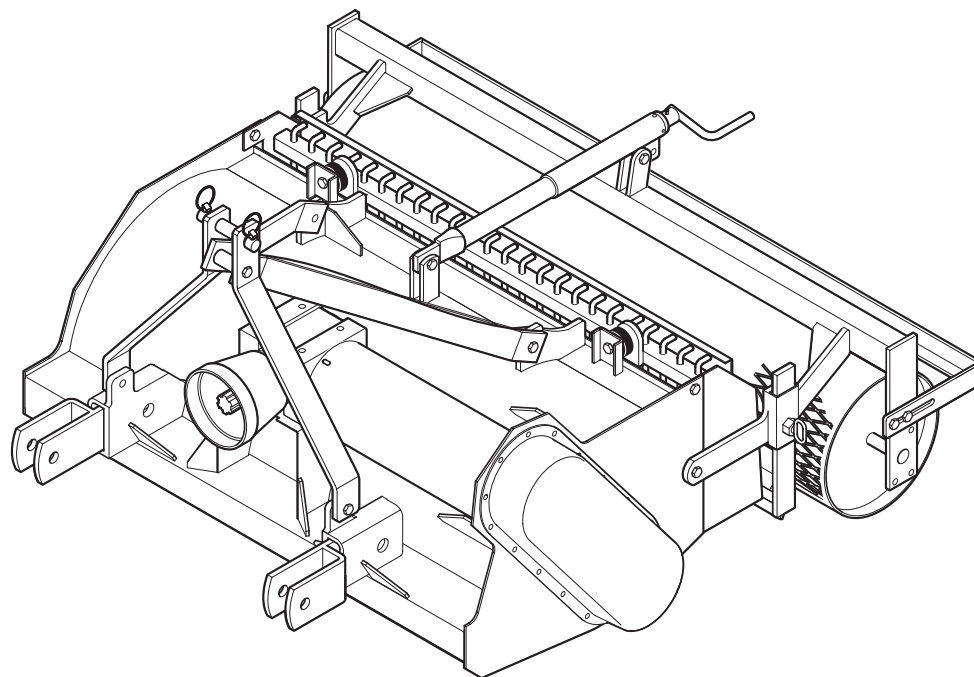

TST-100
TST-113
TST-130
TST-100H
TST-113H
TST-130H



R2 s.a.s. di Rinaldi Roberto & C.

40060 Toscanella di Dozza (Bologna) Italy - Via Valsellustra, 25-29

Tel. +39.0542.672100 • Fax +39.0542.674391

CATALOGO PARTI DI RICAMBIO
SPARE PARTS CATALOGUE
CATALOGUE DE PIECES DETACHEES
ERSATZTEILKATALOG
CATALOGO DE PIEZAS DE REPUESTO

Cod. 060 rev.1

Edizione 03/2008

SIMBOLOGIA • SYMBOLS • SYMBOLES UTILISES • SYMBOLE • SIMBOLOGIA

I

Nella colonna CODICE di ogni distinta può essere presente uno di questi simboli:



Partediricambiomomentaneamente priva di codice.

Per identificarla occorre indicare:

- Numero della tavola
- Numero di posizione
- Modello e matricola della macchina.



Parte di ricambio avente ulteriori parti di ricambio interne.

Per identificare le singole parti interne occorre andare alla tavola di corrispondente denominazione.



Parte di ricambio con variabili dimensionali o di quantità.

Occorre specificare il modello e la matricola della macchina individuabili nell'apposita targhetta.

GB

In the CODED column of each list, you find one of following symbols:



Spare part temporarily uncoded.

To identify the part you must specify:

- Table code
- Position number
- Machine model and serial number.



Spare part consisting of more internal spare parts.

To find the single internal parts, please refer to the relevant description table.



Spare part with dimension or quantity variables.

Always specify the machine model and serial number, given in the identification plate.

F

Dans la colonne CODE de chaque liste Vous pouvez trouver un des symboles suivants:



Pièce de réchange temporairement sans code.

Pour son identification, il faut spécifier:

- Code du tableau
- Numéro de position
- Modèle et numéro de fabrique machine.



Pièce de réchange comprenant des pièces de rechange à l'intérieur.

Pour l'identification de pièces individuelles, se référer au tableau descriptif correspondant.



Pièce détachée avec variables dimensionnelles o de quantité.

Spécifier toujours le modèle et le numéro de fabrique de la machine, donnés sur la plaque d'identification.

D

Die Reihe Anmerkungen jeder CODE kann ein folgender Symbole zeigen:



Ersatzteil hat vorübergehend keinen Code.

Um diesen Ersatzteil angeben zu können, müssen Sie:

- Code Tabelle
- Positionsnummer
- Maschinenmodell und - kennummer.



Ersatzteil hat weitere Ersatzteile auf der Innenseite.

Für die Identifikation der einzelnen Innerteile, die entsprechende Benennungstabelle nachschlagen.



Ersatzteil mit variablen Maßen oder Menge.

Bitte, Modell und Fabriknummer der Maschine, die auf dem Typenschild abgedruckt sind, angeben.

E

La columna CÓDIGO de cada lista puede presentar uno de los símbolos siguientes:



Repuesto actualmente falto de código.

Para la identificación del repuesto es necesario indicar:

- Código tabla
- Número de posición
- Modelo y número de serie máquina.



Ruesto que consta de sucesivos repuestos internos.

Para la identificación de las partes internas distintas, ver tabla descriptiva correspondiente.



Repuesto con variables dimensionales o de cantidad.

Declarar siempre el modelo y el número de serie de la máquina, que se encuentran en la tarjeta de identificación.

COME ORDINARE I RICAMBI • HOW TO ORDER SPARE PARTS • COMMANDE DES PIÈCES DÉTACHÉES • ANFRANGE VON ERSATZTEILEN • PEDIDO DE LOS REPUESTOS

Per ordinare le parti di ricambio Vi preghiamo cortesemente di fornire al Servizio Assistenza tutte le seguenti informazioni:

- Modello, tipo e numero di matricola della macchina.
- Codice, descrizione e quantità delle parti di ricambio che si intendono ordinare.

Inoltre all'ordine sarà necessario precisare:

- Ragione sociale, indirizzo completo, recapito telefonico e telefax.
- Indirizzo completo al quale spedire le parti di ricambio.
- Eventuale mezzo di trasporto/vettore da utilizzare preferenzialmente.

When ordering spare parts, please supply After Sales Service the following information:

- Machine model, type and serial number
- Code, description and quantity of the spare parts you wish to order.

In addition to what above, add also:

- Corporate name, address, phone and fax number.
- Delivery address.
- Preferential transport mean/carrier.

Pour commander les pièces de rechange nous vous prions de bien vouloir transmettre au Service Après-Vente les indications suivantes:

- Modèle, type et numéro de série de la machine.
- Code, description et quantité des pièces de rechange commandées.

De plus, indiquer dans la commande:

- Nom de la société, adresse complète, numéro de téléphone et de télécopieur.
- Adresse complète pour l'expédition.
- Eventuel moyen de transport/expéditeur préférentiel.

Um Ersatzteil zu bestellen, bitten wir Sie höflichst, dem Kundendienst alle nachfolgend angeführten Angaben zu machen:

- Modell, Typ und Matrikel-Nr. der Maschine.
- Code, Beschreibung und Anzahl der Ersatzteile, die man bestellen möchte.

Außerdem sollte man bei der Bestellung angeben:

- Name der Firma, vollständige Adresse, Telefon und Fax-nummer.
- Vollständige Adresse, an die Ersatzteile zu senden sind.
- Von Ihnen gewünschtes Transportmittel / Transport-unternehmen.

Para el pedido de repuestos, Le rogamos se sirvan suministrar al Servicio Asistencia todas las indicaciones siguientes:

- Modelo, tipo y número de matricula de la máquina.
- Código, descripción y cantidad de los repuestos pedido.

Además, se ruega detallar lo siguiente:

- Razón social, dirección completa, teléfono y telefax.
- Dirección completa a la que se deben enviar los repuestos.
- Eventual medio/agente de transporte que se desea utilizar.

INDICE DELLE TAVOLE • TABLE INDEX • INDEX DES TABLEAUX

01.0	MONTAGGIO RULLO POSTERIORE E GRIGLIA (TST 100)	REAR ROLLER AND GRATE ASSEMBLY (TST 100)	MONTAGE ROULEAUX ARRIERE ET GRILLAGE (TST 100)
02.0	MONTAGGIO RULLO POSTERIORE E GRIGLIA (TST 113)	REAR ROLLER AND GRATE ASSEMBLY (TST 113)	MONTAGE ROULEAUX ARRIERE ET GRILLAGE (TST 113)
03.0	MONTAGGIO RULLO POSTERIORE E GRIGLIA (TST 130)	REAR ROLLER AND GRATE ASSEMBLY (TST 130)	MONTAGE ROULEAUX ARRIERE ET GRILLAGE (TST 130)
04.0	TRASMISSIONE (TST 100)	TRANSMISSION (TST 100)	TRANSMISSION (TST 100)
05.0	TRASMISSIONE (TST 113)	TRANSMISSION (TST 113)	TRANSMISSION (TST 113)
06.0	TRASMISSIONE (TST 130)	TRANSMISSION (TST 130)	TRANSMISSION (TST 130)
07.0	TELAIO - CARTER E ACCESSORI (TST 100-113-130)	FRAME - COVERS AND ACCESSORIES (TST 100-113-130)	CHASSIS - CARTERS ET ACCESSOIRES (TST 100-113-130)
08.0	TRASMISSIONE IDRAULICA (TST 100H)	HYDRAULIC TRANSMISSION (TST 100H)	TRANSMISSION HYDRAULIQUE (TST 100H)
09.0	TRASMISSIONE IDRAULICA (TST 113H)	HYDRAULIC TRANSMISSION (TST 113H)	TRANSMISSION HYDRAULIQUE (TST 113H)
10.0	TRASMISSIONE IDRAULICA (TST 130H)	HYDRAULIC TRANSMISSION (TST 130H)	TRANSMISSION HYDRAULIQUE (TST 130H)

TABELLEN-VERZEICHNIS • INDICE DE LAS TABLAS

01.0	MONTAGE HINTERE ROLLEN UND GITTERROST (TST 100)	MONTAGE RODILLOS TRASERO Y ENREJADO (TST 100)
02.0	MONTAGE HINTERE ROLLEN UND GITTERROST (TST 113)	MONTAGE RODILLOS TRASERO Y ENREJADO (TST 113)
03.0	MONTAGE HINTERE ROLLEN UND GITTERROST (TST 130)	MONTAGE RODILLOS TRASERO Y ENREJADO (TST 130)
04.0	TRANSMISSION (TST 100)	TRANSMISIÓN (TST 100)
05.0	TRANSMISSION (TST 113)	TRANSMISIÓN (TST 113)
06.0	TRANSMISSION (TST 130)	TRANSMISIÓN (TST 130)
07.0	RAHMEN - SCHUTZABDECKUNGEN UND ZEBÖHR (TST 100-113-130)	BASTIDOR - CÁRTERES Y ACCESORIOS (TST 100-113-130)
08.0	HYDRAULIKANTRIEB (TST 100H)	TRANSMISIÓN HIDRÁULICA (TST 100H)
09.0	HYDRAULIKANTRIEB (TST 113H)	TRANSMISIÓN HIDRÁULICA (TST 113H)
10.0	HYDRAULIKANTRIEB (TST 130H)	TRANSMISIÓN HIDRÁULICA (TST 130H)



MONTAGGIO RULLO POSTERIORE E GRIGLIA
REAR ROLLER AND GRATE ASSEMBLY
MONTAGE ROULEAUX ARRIERE ET GRILLAGE
MONTAGE HINTERE ROLLEN UND GITTERROST
MONTAGE RODILLOS TRASERO Y ENREJADO

Tav. 01.0

TST-100

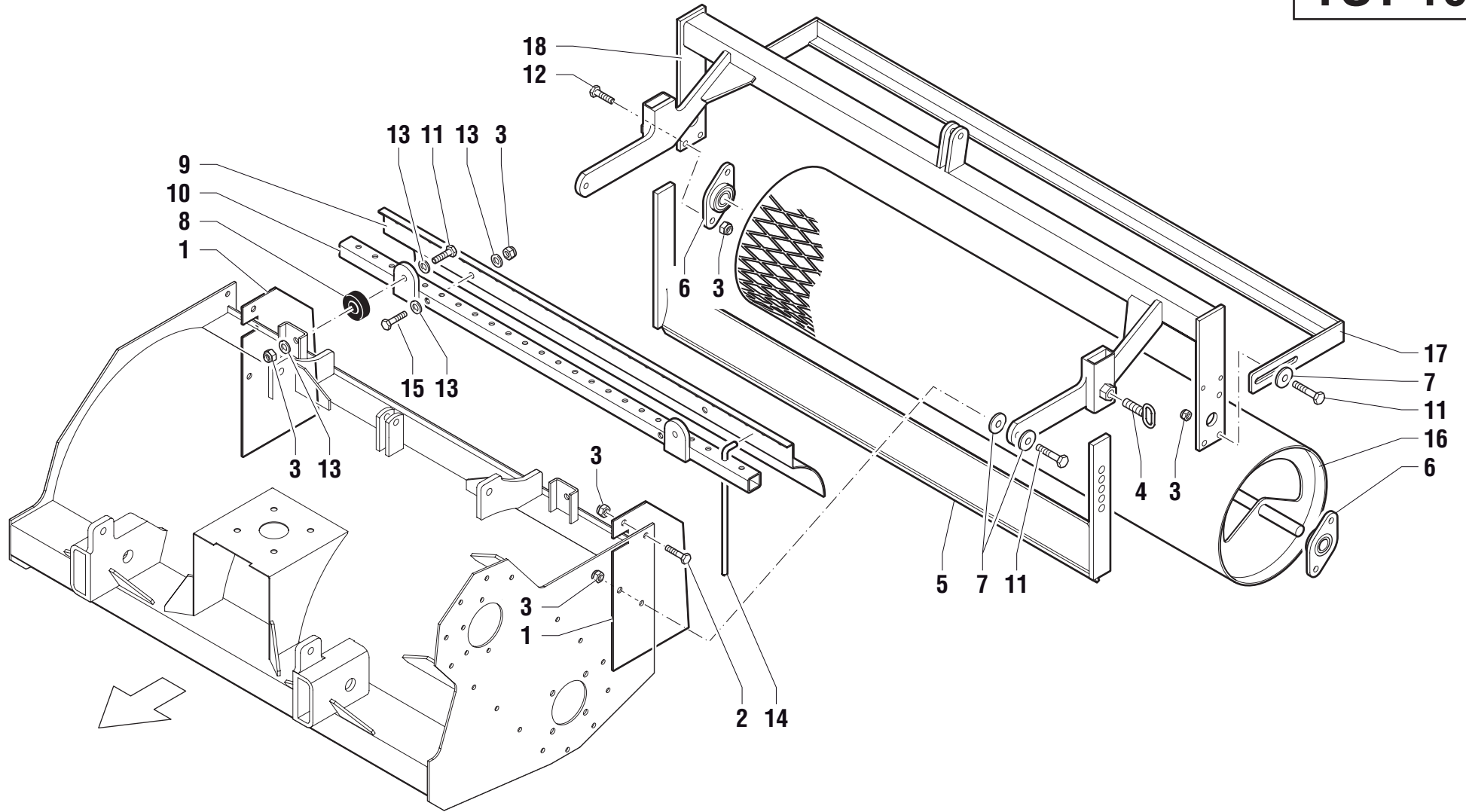



MONTAGGIO RULLO POSTERIORE E GRIGLIA
REAR ROLLER AND GRATE ASSEMBLY
MONTAGE ROULEAUX ARRIERE ET GRILLAGE
MONTAGE HINTERE ROLLEN UND GITTERROST
MONTAGE RODILLOS TRASERO Y ENREJADO

Tav. 03.0

TST-130

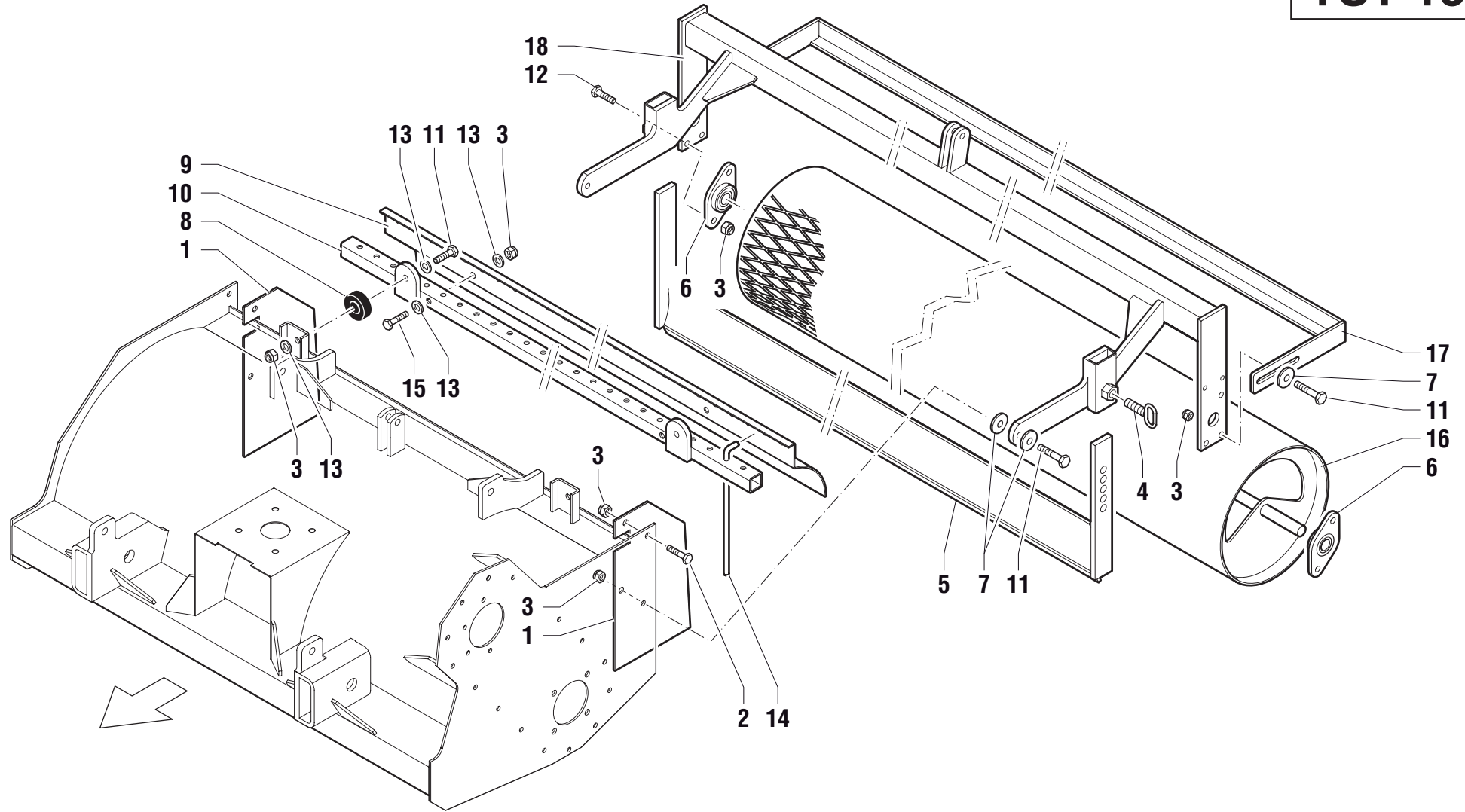



TRASMISSIONE
TRANSMISSION
TRANSMISSION
TRANSMISSION
TRANSMISSION

Tav. 04.0

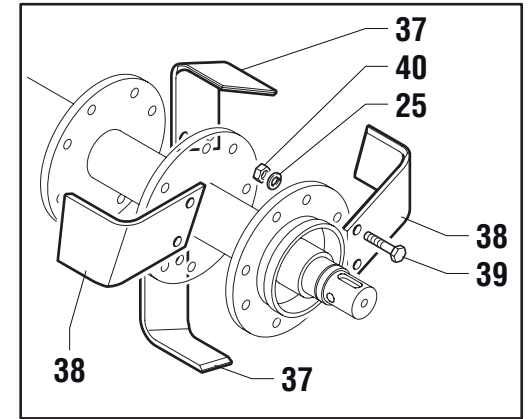
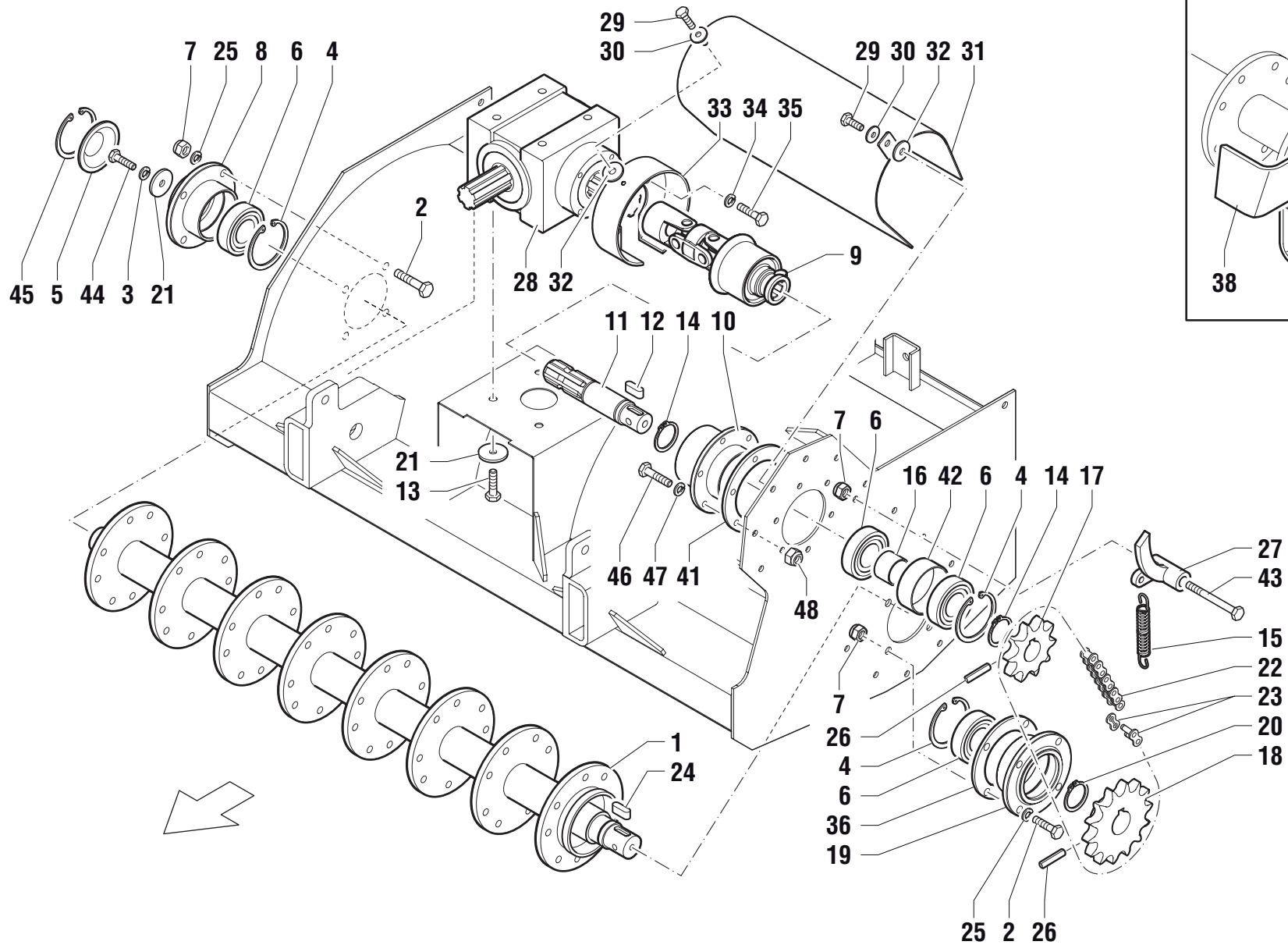

TST-100

<i>Rif.</i>	<i>CODICE</i>	<i>Qty</i>	<i>Descrizione</i>	<i>Description</i>	<i>Designation</i>	<i>Benennung</i>	<i>Denominaciones</i>
1	060.003	1	ALBERO PORTACOLTELLI	CUTTER HOLDING SHAFT	ARBRE PORTE COUTEAUX	MESSERWELLE	ÁRBOL PORTA CUCHILLAS
2	21.0.0.10030	8	VITE	SCREW	VIS	SCHRAUBE	TORNILLO
3	16.01.00.010	1	RONDELLA ELASTICA	SPRING WASHER	RONDELLE ELASTIQUE	FEDERSCHEIBE	ARANDELA ELASTICA
4	18.00.01.072	3	ANELLO ELASTICO	SNAP RING	ANNEAU RESSORT	SICHERUNGSRING	ANILLO ELASTICO
5	060.087	1	COPERCHIO	COVER	COUVERCLE	DECKEL	TAPA
6	A6207	4	CUSCINETTO	BEARING	PALIER	LAGERSCHALE	COJINETE
7	30.01.00.010	9	DADO AUTOBLOCCANTE	STOP NUT	ECROU DE SURETE	SPERRMUTTER	TUERCA AUTOTRABADORA
8	060.006	1	MOZZO PORTA ALBERO	SHAFT HUB	MOYEU ARBRE	WELLENNABE	CUBO EJE
9	050.111	1	GIUNTO CON LIMITATORE	JOINT WITH LIMIT STOP	JOINT AVEC BUTEE	GELENK MIT ENDANSCHLAG	JUNTA CON LIMITADOR
10	060.007	1	MOZZO PORTA ALBERO	SHAFT HUB	MOYEU ARBRE	WELLENNABE	CUBO EJE
11	060.009	1	ALBERO DI TRASMISSIONE	PROPELLER SHAFT	ARBRE DE TRANSMISSION	WELLE TRANSMISSION	ARBOL DE TRANSMISIÓN
12	35.1.0.08030	1	LINGUETTA	KEY	CLAVETTE	KEIL	CHAVETA
13	21.0.0.10030	1	VITE	SCREW	VIS	SCHRAUBE	TORNILLO
14	18.01.00.035	2	ANELLO ELASTICO	SNAP RING	ANNEAU RESSORT	SICHERUNGSRING	ANILLO ELASTICO
15	050.117	1	MOLLA	SPRING	RESSORT	FEDER	RESORTE
16	031.045	1	DISTANZIALE	SPACER	ENTRETOISE	ABSTANDSTUECK	SEPARADOR
17	060.013	1	PIGNONE	PINION	PIGNON	RITZEL	PINON
18	060.014	1	CORONA	RING GEAR	COURONNE	KRANZ	CORONA
19	060.005	1	MOZZO PORTA ALBERO	SHAFT HUB	MOYEU ARBRE	WELLENNABE	CUBO EJE
20	18.01.00.040	1	ANELLO ELASTICO	SNAP RING	ANNEAU RESSORT	SICHERUNGSRING	ANILLO ELASTICO
21	15.1.0.01.010	2	RONDELLA	WASHER	RONDELLE	SCHEIBE	ARANDELA
22	050.105	1	CATENA	CHAIN	CHAÎNE	KETTE	CADENA
23	050.105/A	1	MAGLIA DI GIUNZIONE	CHAIN JOINT	JOINT DE CHAÎNE	STECKGLIED	UNIÓN DE CADENA
24	35.1.0.10030	1	LINGUETTA	KEY	CLAVETTE	KEIL	CHAVETA
25	16.01.01.010	16	RONDELLA ELASTICA	SPRING WASHER	RONDELLE ELASTIQUE	FEDERSCHEIBE	ARANDELA ELASTICA
26	38.1.1.10050	2	SPINA ELASTICA	SPLIT PIN	BROCHE ELASTIQUE	ZAPFEN FEDRIG	PERNO ELASTICO
27	060.016	1	TENDICATENA	CHAIN STRETCHER	TENDEUR DE CHAINE	KETTENSPIANN	TENJOR DE CADENA
28	050.109	1	RIDUTTORE	REDUCTION GEAR	REDUCTEUR	REDUKTIONSGETRIEBE	REDUCTOR
29	21.0.0.06020	2	VITE	SCREW	VIS	SCHRAUBE	TORNILLO
30	15.0.0.00.006	2	RONDELLA PIANA	PLAIN WASHER	RONDELLE PLANE	ABSTANDSRING	ARANDELA LLANA
31	060.063	1	CARTER DI PROTEZIONE	GUARD	PROTECTION	SCHUTZKASTEN	PROTECCIÓN





TRASMISSIONE
TRANSMISSION
TRANSMISSION
TRANSMISSION
TRANSMISSION

Tav. 04.0

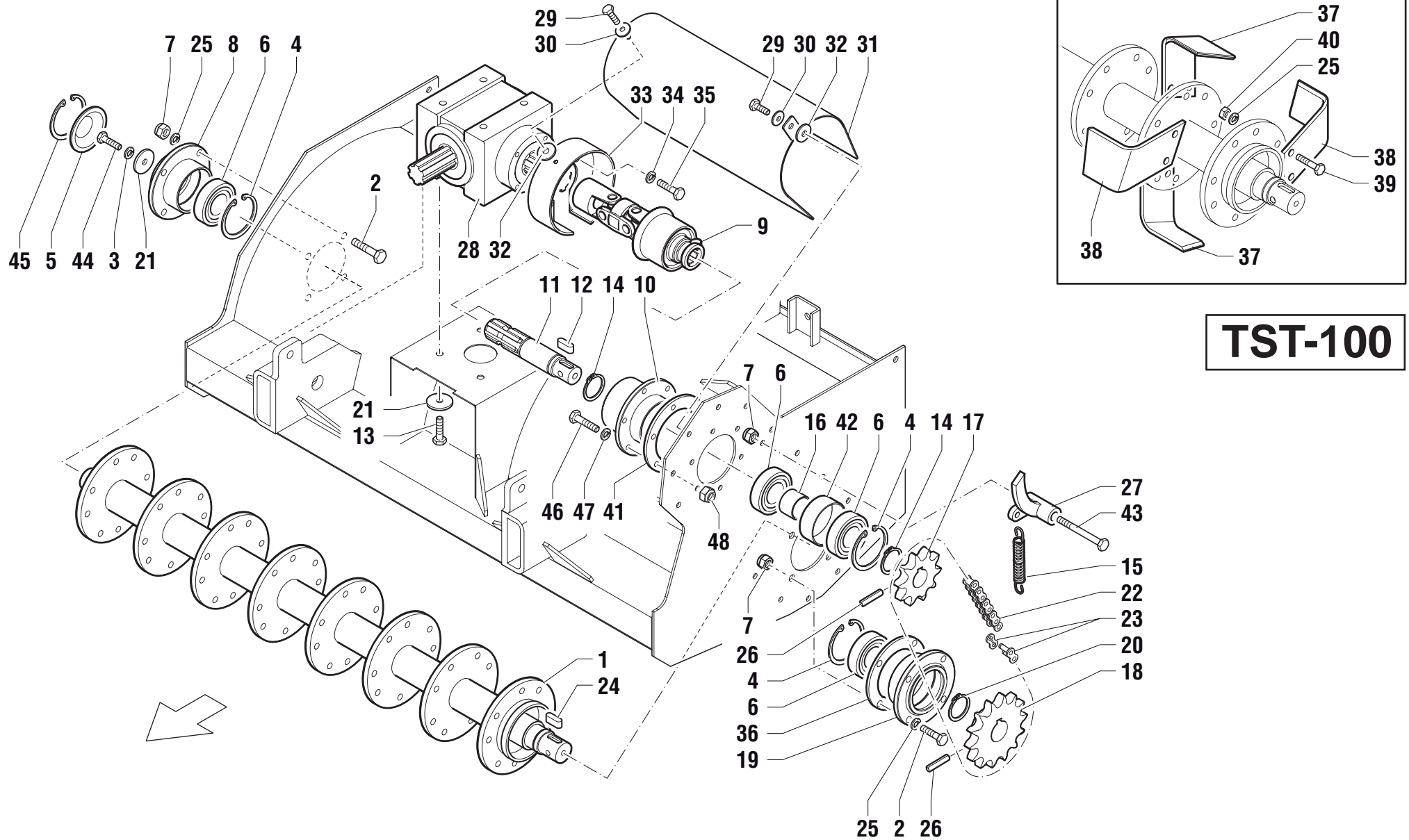



TRASMISSIONE
TRANSMISSION
TRANSMISSION
TRANSMISSION
TRANSMISSION

Tav. 05.0

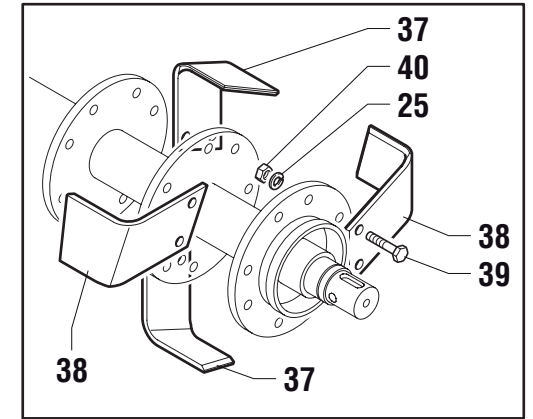
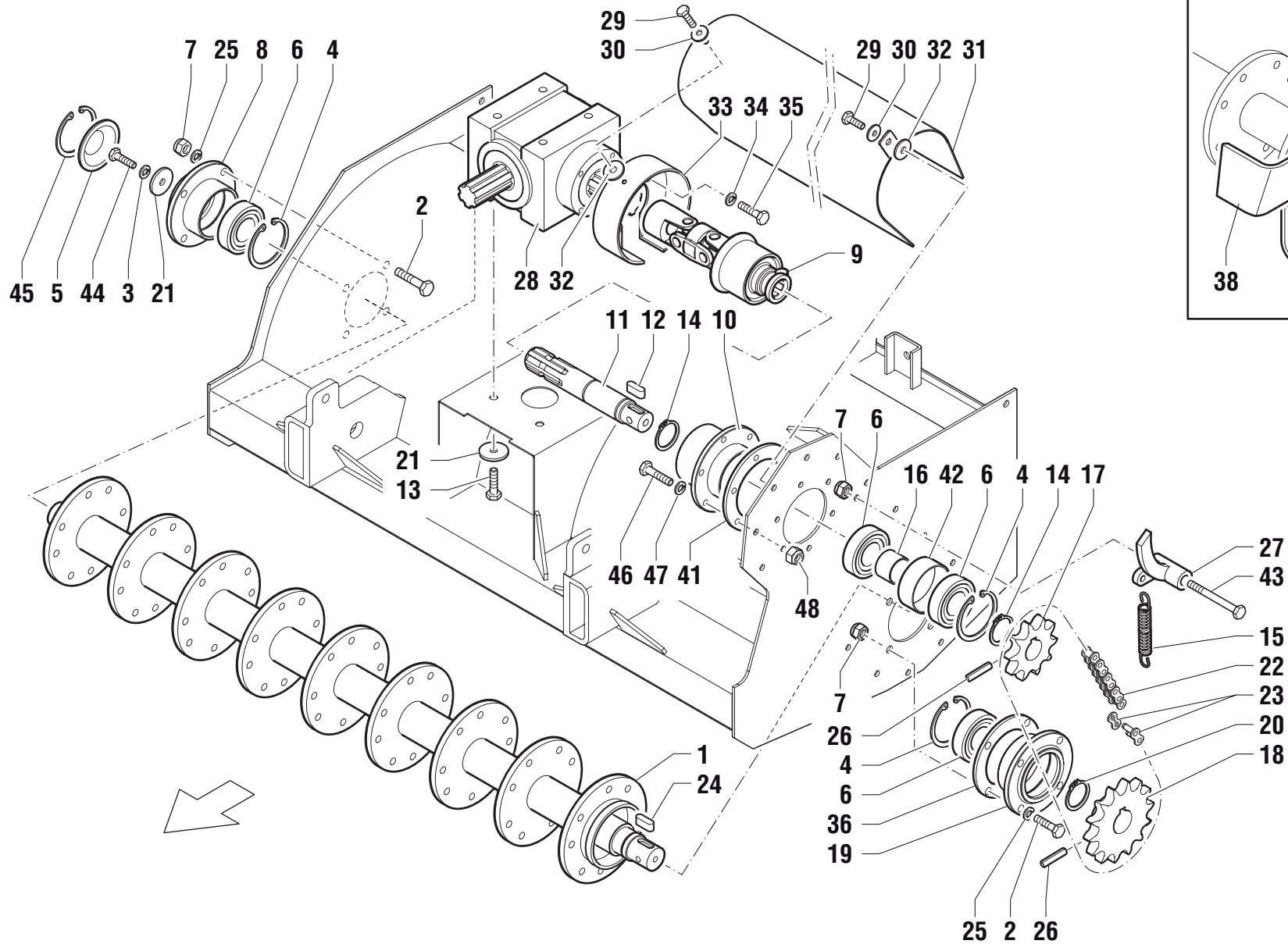

TST-113

<i>Rif.</i>	<i>CODICE</i>	<i>Qty</i>	<i>Descrizione</i>	<i>Description</i>	<i>Designation</i>	<i>Benennung</i>	<i>Denominaciones</i>
1	060.047	1	ALBERO PORTACOLTELLI	CUTTER HOLDING SHAFT	ARBRE PORTE COUTEAUX	MESSERWELLE	ÁRBOL PORTRA CUCHILLAS
2	21.0.0.10030	8	VITE	SCREW	VIS	SCHRAUBE	TORNILLO
3	16.01.00.010	1	RONDELLA ELASTICA	SPRING WASHER	RONDELLE ELASTIQUE	FEDERSCHEIBE	ARANDELA ELASTICA
4	18.00.01.072	3	ANELLO ELASTICO	SNAP RING	ANNEAU RESSORT	SICHERUNGSRING	ANILLO ELASTICO
5	060.087	1	COPERCHIO	COVER	COUVERCLE	DECKEL	TAPA
6	A6207	4	CUSCINETTO	BEARING	PALIER	LAGERSCHALE	COJINETE
7	30.01.00.010	9	DADO AUTOBLOCCANTE	STOP NUT	ECROU DE SURETE	SPERRMUTTER	TUERCA AUTOTRABADORA
8	060.006	1	MOZZO PORTA ALBERO	SHAFT HUB	MOYEU ARBRE	WELLENNABE	CUBO EJE
9	050.249	1	GIUNTO CON LIMITATORE	JOINT WITH LIMIT STOP	JOINT AVEC BUTEE	GELENK MIT ENDANSCHLAG	JUNTA CON LIMITADOR
10	060.007	1	MOZZO PORTA ALBERO	SHAFT HUB	MOYEU ARBRE	WELLENNABE	CUBO EJE
11	060.069	1	ALBERO DI TRASMISSIONE	PROPELLER SHAFT	ARBRE DE TRANSMISSION	WELLE TRANSMISSION	ARBOL DE TRANSMISIÓN
12	35.1.0.08030	1	LINGUETTA	KEY	CLAVETTE	KEIL	CHAVETA
13	21.0.0.10030	1	VITE	SCREW	VIS	SCHRAUBE	TORNILLO
14	18.01.00.035	2	ANELLO ELASTICO	SNAP RING	ANNEAU RESSORT	SICHERUNGSRING	ANILLO ELASTICO
15	050.117	1	MOLLA	SPRING	RESSORT	FEDER	RESORTE
16	031.045	1	DISTANZIALE	SPACER	ENTRETOISE	ABSTANDSTUECK	SEPARADOR
17	060.013	1	PIGNONE	PINION	PIGNON	RITZEL	PINON
18	060.014	1	CORONA	RING GEAR	COURONNE	KRANZ	CORONA
19	060.005	1	MOZZO PORTA ALBERO	SHAFT HUB	MOYEU ARBRE	WELLENNABE	CUBO EJE
20	18.01.00.040	1	ANELLO ELASTICO	SNAP RING	ANNEAU RESSORT	SICHERUNGSRING	ANILLO ELASTICO
21	15.1.0.01.010	2	RONDELLA	WASHER	RONDELLE	SCHEIBE	ARANDELA
22	050.105	1	CATENA	CHAIN	CHAÎNE	KETTE	CADENA
23	050.105/A	1	MAGLIA DI GIUNZIONE	CHAIN JOINT	JOINT DE CHAÎNE	STECKGLIED	UNIÓN DE CADENA
24	35.1.0.10030	1	LINGUETTA	KEY	CLAVETTE	KEIL	CHAVETA
25	16.01.01.010	24	RONDELLA ELASTICA	SPRING WASHER	RONDELLE ELASTIQUE	FEDERSCHEIBE	ARANDELA ELASTICA
26	38.1.1.10050	2	SPINA ELASTICA	SPLIT PIN	BROCHE ELASTIQUE	ZAPFEN FEDRIG	PERNO ELASTICO
27	060.016	1	TENDICATENA	CHAIN STRETCHER	TENDEUR DE CHAINE	KETTENSPIANN	TENJOR DE CADENA
28	050.109	1	RIDUTTORE	REDUCTION GEAR	REDUCTEUR	REDUKTIONSGETRIEBE	REDUCTOR
29	21.0.0.06020	2	VITE	SCREW	VIS	SCHRAUBE	TORNILLO
30	15.0.0.00.006	2	RONDELLA PIANA	PLAIN WASHER	RONDELLE PLANE	ABSTANDSRING	ARANDELA LLANA
31	060.048	1	CARTER DI PROTEZIONE	GUARD	PROTECTION	SCHUTZKASTEN	PROTECCIÓN





TRASMISSIONE
TRANSMISSION
TRANSMISSION
TRANSMISSION
TRANSMISSION

Tav. 05.0

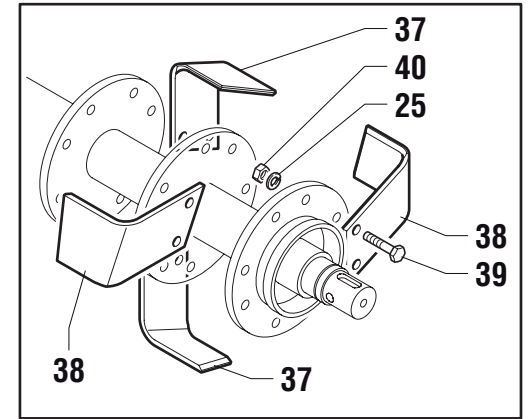
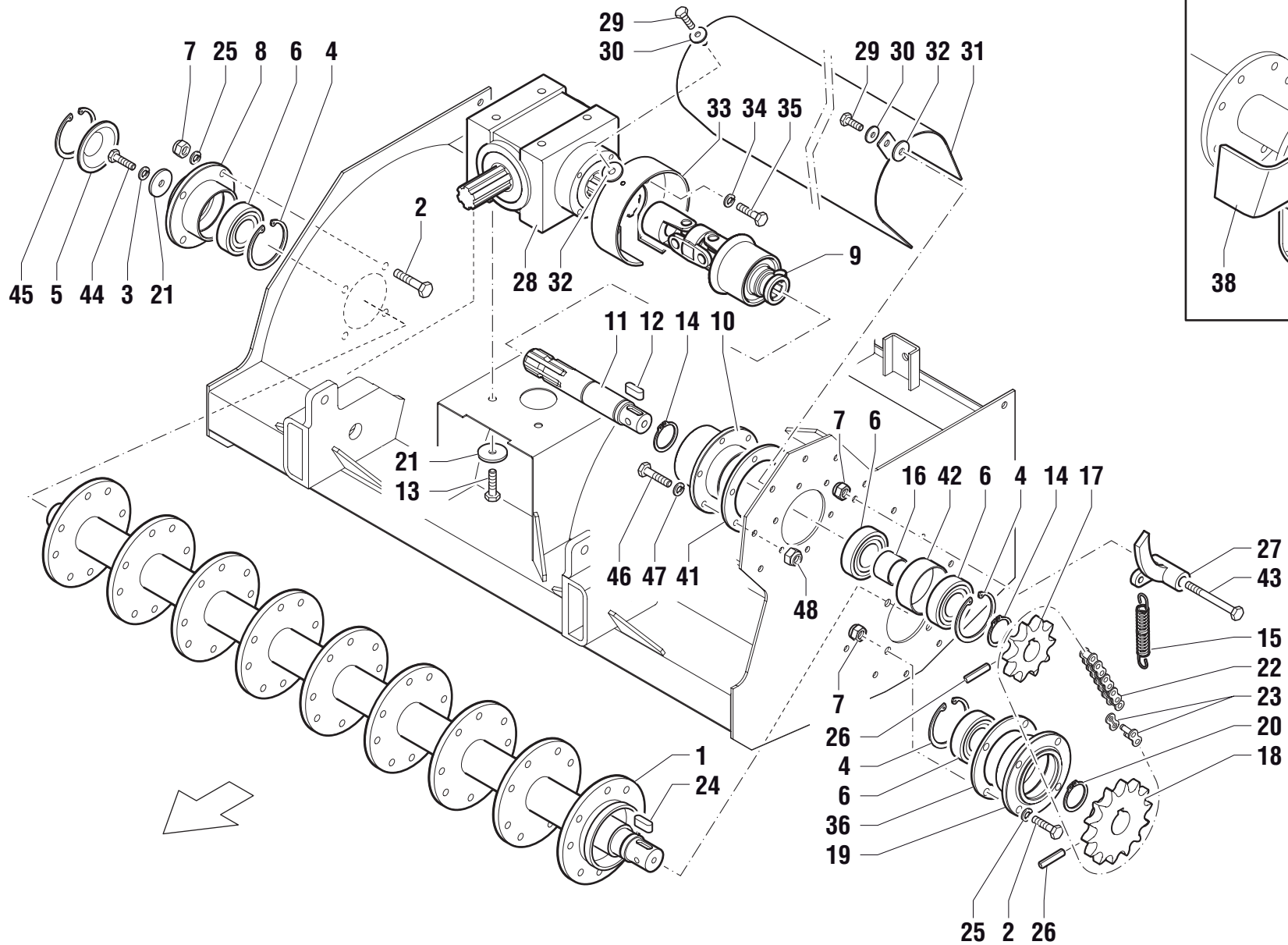

TST-113



TRASMISSIONE
TRANSMISSION
TRANSMISSION
TRANSMISSION
TRANSMISSION

Tav. 06.0

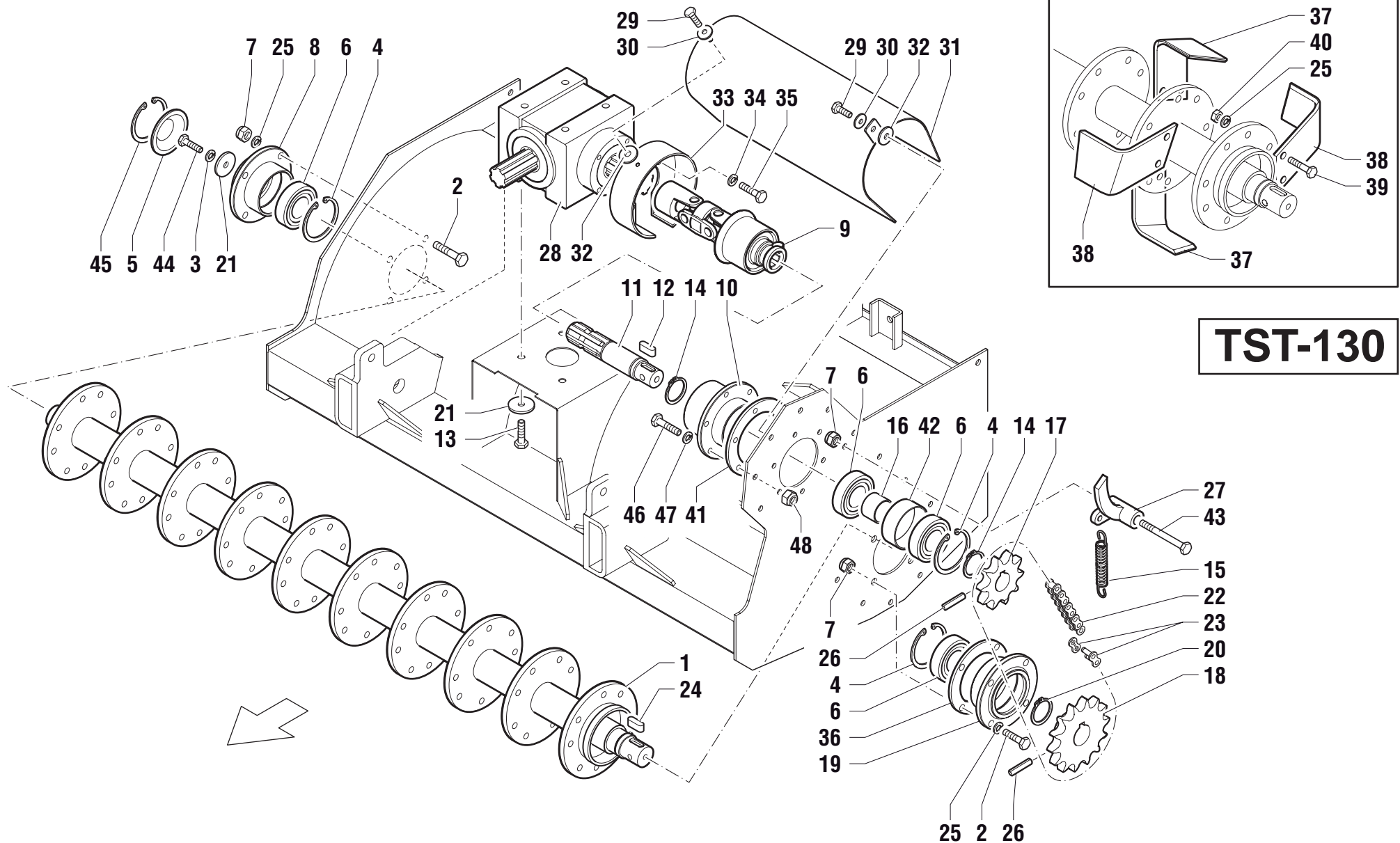

TST-130

<i>Rif.</i>	<i>CODICE</i>	<i>Qty</i>	<i>Descrizione</i>	<i>Description</i>	<i>Designation</i>	<i>Benennung</i>	<i>Denominaciones</i>
1	060.044	1	ALBERO PORTACOLTELLI	CUTTER HOLDING SHAFT	ARBRE PORTE COUTEAUX	MESSERWELLE	ÁRBOL PORTRA CUCHILLAS
2	21.0.0.10030	8	VITE	SCREW	VIS	SCHRAUBE	TORNILLO
3	16.01.00.010	1	RONDELLA ELASTICA	SPRING WASHER	RONDELLE ELASTIQUE	FEDERSCHEIBE	ARANDELA ELASTICA
4	18.00.01.072	3	ANELLO ELASTICO	SNAP RING	ANNEAU RESSORT	SICHERUNGSRING	ANILLO ELASTICO
5	060.087	1	COPERCHIO	COVER	COUVERCLE	DECKEL	TAPA
6	A6207	4	CUSCINETTO	BEARING	PALIER	LAGERSCHALE	COJINETE
7	30.01.00.010	9	DADO AUTOBLOCCANTE	STOP NUT	ECROU DE SURETE	SPERRMUTTER	TUERCA AUTOTRABADORA
8	060.006	1	MOZZO PORTA ALBERO	SHAFT HUB	MOYEU ARBRE	WELLENNABE	CUBO EJE
9	050.341	1	GIUNTO CON LIMITATORE	JOINT WITH LIMIT STOP	JOINT AVEC BUTEE	GELENK MIT ENDANSCHLAG	JUNTA CON LIMITADOR
10	060.007	1	MOZZO PORTA ALBERO	SHAFT HUB	MOYEU ARBRE	WELLENNABE	CUBO EJE
11	060.106	1	ALBERO DI TRASMISSIONE	PROPELLER SHAFT	ARBRE DE TRANSMISSION	WELLE TRANSMISSION	ARBOL DE TRANSMISIÓN
12	35.1.0.08030	1	LINGUETTA	KEY	CLAVETTE	KEIL	CHAVETA
13	21.0.0.10030	1	VITE	SCREW	VIS	SCHRAUBE	TORNILLO
14	18.01.00.035	2	ANELLO ELASTICO	SNAP RING	ANNEAU RESSORT	SICHERUNGSRING	ANILLO ELASTICO
15	050.117	1	MOLLA	SPRING	RESSORT	FEDER	RESORTE
16	031.045	1	DISTANZIALE	SPACER	ENTRETOISE	ABSTANDSTUECK	SEPARADOR
17	060.013	1	PIGNONE	PINION	PIGNON	RITZEL	PINON
18	060.014	1	CORONA	RING GEAR	COURONNE	KRANZ	CORONA
19	060.005	1	MOZZO PORTA ALBERO	SHAFT HUB	MOYEU ARBRE	WELLENNABE	CUBO EJE
20	18.01.00.040	1	ANELLO ELASTICO	SNAP RING	ANNEAU RESSORT	SICHERUNGSRING	ANILLO ELASTICO
21	15.1.0.01.010	2	RONDELLA	WASHER	RONDELLE	SCHEIBE	ARANDELA
22	050.105	1	CATENA	CHAIN	CHAÎNE	KETTE	CADENA
23	050.105/A	1	MAGLIA DI GIUNZIONE	CHAIN JOINT	JOINT DE CHAÎNE	STECKGLIED	UNIÓN DE CADENA
24	35.1.0.10030	1	LINGUETTA	KEY	CLAVETTE	KEIL	CHAVETA
25	16.01.01.010	24	RONDELLA ELASTICA	SPRING WASHER	RONDELLE ELASTIQUE	FEDERSCHEIBE	ARANDELA ELASTICA
26	38.1.1.10050	2	SPINA ELASTICA	SPLIT PIN	BROCHE ELASTIQUE	ZAPFEN FEDRIG	PERNO ELASTICO
27	060.016	1	TENDICATENA	CHAIN STRETCHER	TENDEUR DE CHAINE	KETTENSPIANN	TENJOR DE CADENA
28	050.109	1	RIDUTTORE	REDUCTION GEAR	REDUCTEUR	REDUKTIONSGETRIEBE	REDUCTOR
29	21.0.0.06020	2	VITE	SCREW	VIS	SCHRAUBE	TORNILLO
30	15.0.0.00.006	2	RONDELLA PIANA	PLAIN WASHER	RONDELLE PLANE	ABSTANDSRING	ARANDELA LLANA
31	060.110	1	CARTER DI PROTEZIONE	GUARD	PROTECTION	SCHUTZKASTEN	PROTECCIÓN





TRASMISSIONE
TRANSMISSION
TRANSMISSION
TRANSMISSION
TRANSMISSION

Tav. 06.0

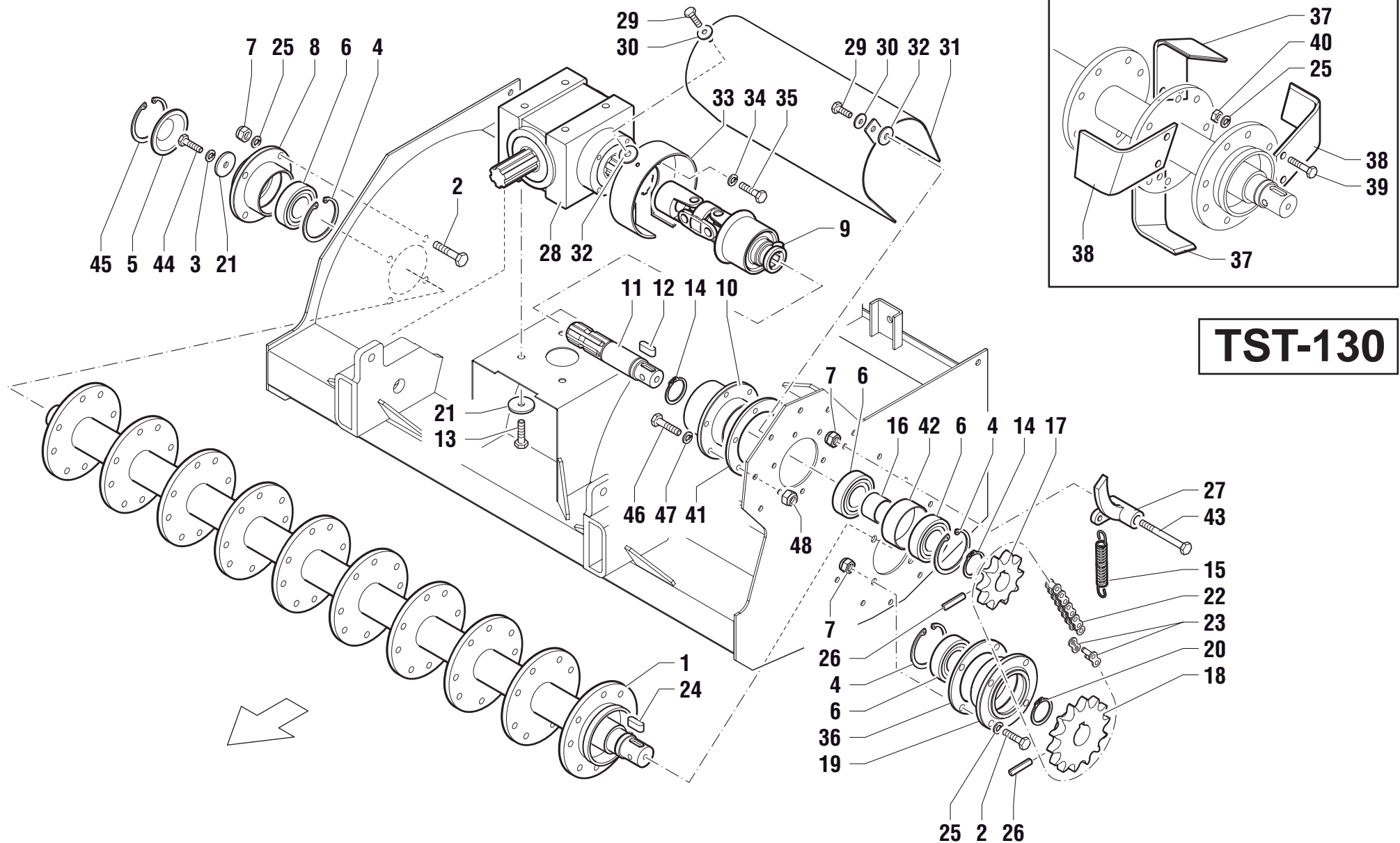

TST-130



TELAIO - CARTER E ACCESSORI
FRAME - COVERS AND ACCESSORIES
CHASSIS - CARTERS ET ACCESSOIRES
RAHMEN - SCHUTZABDECKUNGEN UND ZEBÖHR
BASTIDOR - CÂRTERES Y ACCESORIOS

Tav. 07.0

TST-100

TST-113

TST-130

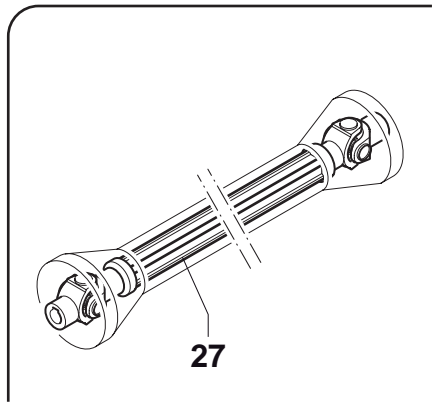
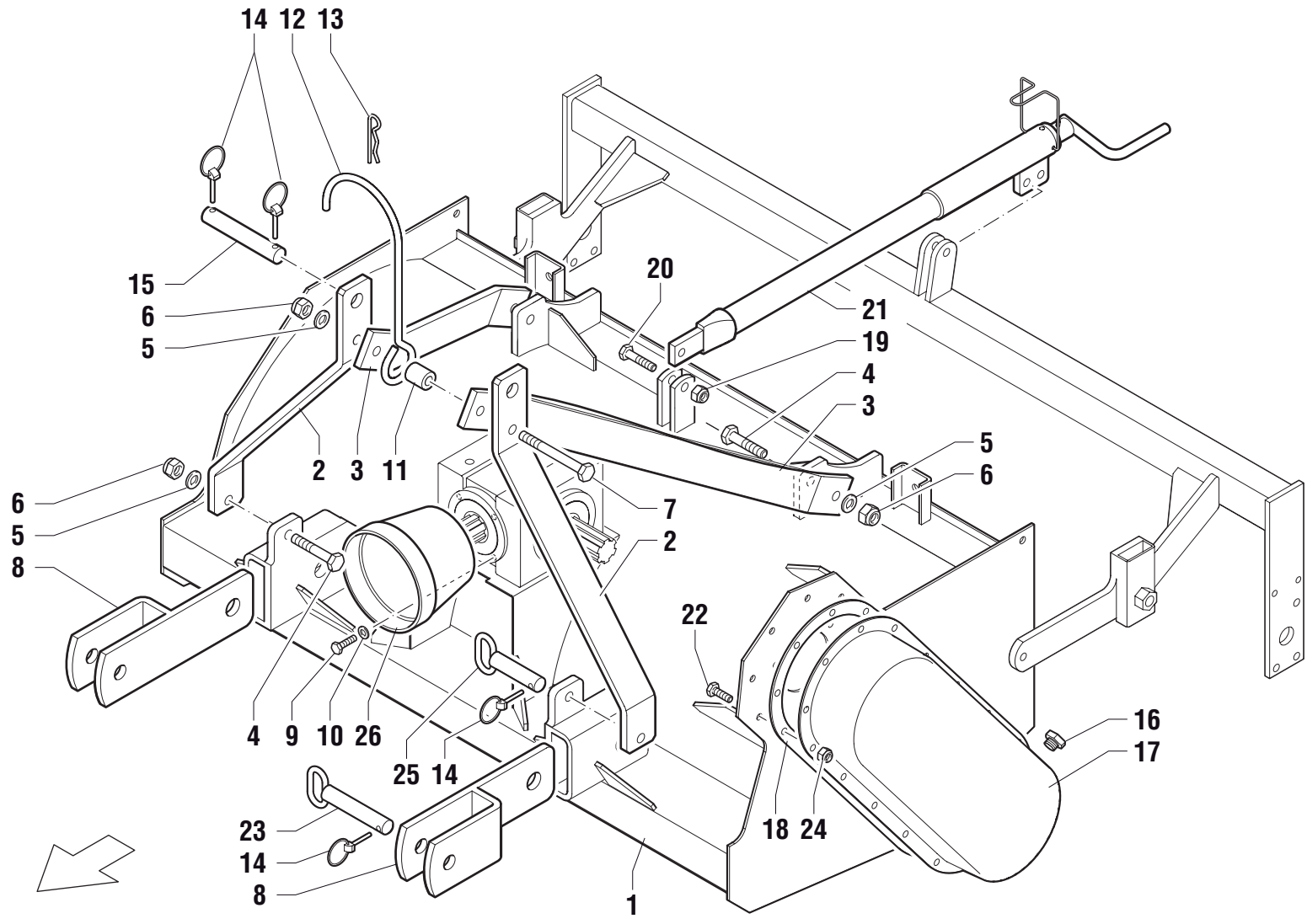

<i>Rif.</i>	<i>CODICE</i>	<i>Qty</i>	<i>Descrizione</i>	<i>Description</i>	<i>Designation</i>	<i>Benennung</i>	<i>Denominaciones</i>
1	060.001	1	TELAIO TST-100	FRAME	CHASSIS	RAHMEN	BASTIDOR
1	060.050	1	TELAIO TST-113	FRAME	CHASSIS	RAHMEN	BASTIDOR
1	060.105	1	TELAIO TST-130	FRAME	CHASSIS	RAHMEN	BASTIDOR
2	034.008	2	LAMA ANTERIORE	FRONT TIE-ROD	TIRANT AVANT	VORDERE ZUGSTANGE	TIRANTE ANTERIOR
3	034.009	2	LAMA POSTERIORE	REAR TIE-ROD	TIRANT ARRIERE	HINTERE ZUGSTANGE	TIRANTE POSTERIOR
4	20.0.0.12045	4	VITE	SCREW	VIS	SCHRAUBE	TORNILLO
5	15.0.0.00.012	5	RONDELLA PIANA	PLAIN WASHER	RONDELLE PLANE	ABSTANDSRING	ARANDELA LLANA
6	30.02.00.012	5	DADO AUTOBLOCCANTE	STOP NUT	ECROU DE SURETE	SPERRMUTTER	TUERCA AUTOTRABADORA
7	20.0.0.12090	1	VITE	SCREW	VIS	SCHRAUBE	TORNILLO
8	060.026	2	BRACCIO	ARM	BRAS	ARM	BRAZO
9	21.0.0.08016	4	VITE	SCREW	VIS	SCHRAUBE	TORNILLO
10	15.0.0.00.008	4	RONDELLA PIANA	PLAIN WASHER	RONDELLE PLANE	ABSTANDSRING	ARANDELA LLANA
11	034.012	1	DISTANZIALE	SPACER	ENTRETOISE	ABSTANDSTUECK	SEPARADOR
12	093.140	1	GANCIO	HOOK	CROCHET	HAKEN	GANCHO
13		1	COPIGLIA A "R"	COTTER PIN	GOUPILLE	SPLINT	CLAVIJA
14	050.159	1	SPINOTTO A SCATTO	RELEASE PIN	BROCHE DE SÛRETE	SPRINGSTECKER	PASADOR DISPARO
15	000.017	1	PERNO	PIN	PIVOT	BOLZEN	PERNO
16	050.001	1	TAPPO	PLUG	BOUCHON	STOPFEN	TAPÓN
17	060.004	1	CARTER CATENA	CHAIN CASING	CARTER CHAINE	GEHÄUSEKETTE	CARTER CADENA
18	050.106	1	GUARNIZIONE	SEAL	JOINT	DICHTUNG	GUARNICIÓN
19	30.02.00.010	2	DADO AUTOBLOCCANTE	STOP NUT	ECROU DE SURETE	SPERRMUTTER	TUERCA AUTOTRABADORA
20	20.0.0.10045	2	VITE	SCREW	VIS	SCHRAUBE	TORNILLO
21	060.030	1	REGISTRO	ADJUSTER	REGLAGE	REGULATOR	AJUSTE
22	21.0.1.08016	16	VITE	SCREW	VIS	SCHRAUBE	TORNILLO
23	000.016	2	PERNO LUNGO	HIGH PIN	TOURILLON LONG	HOHER BOLZEN	PERNO ALTO
24	30.01.00.008	16	DADO AUTOBLOCCANTE	STOP NUT	ECROU DE SURETE	SPERRMUTTER	TUERCA AUTOTRABADORA
25	000.056	2	PERNO CORTO	THIN PIN	TOURILLON COURT	NIEDRIGER BOLZEN	PERNO BAJO
26	050.052	1	CUFFIA GIUNTO	JOINT HOUSING	PROTECTEUR JOINT	KUPPLUNGSMANSCHETTE	PROTECCIÓN ARTICULACIÓN
27	050.035	1	ALBERO CARDANICO L=550	CARDAN SHAFT	ARBRE CARDAN	KARDANWELLE	ARBOL CARDANICO
27	050.128	1	ALBERO CARDANICO L=600	CARDAN SHAFT	ARBRE CARDAN	KARDANWELLE	ARBOL CARDANICO
27	050.216	1	ALBERO CARDANICO L=700	CARDAN SHAFT	ARBRE CARDAN	KARDANWELLE	ARBOL CARDANICO



Tav. 07.0



TRASMISSIONE IDRAULICA
HYDRAULIC TRANSMISSION
TRANSMISSION HYDRAULIQUE
HYDRAULIKANTRIEB
TRANSMISIÓN HIDRÁULICA

Tav. 08.0

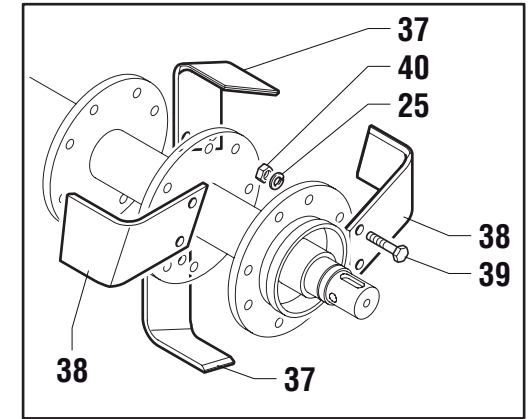
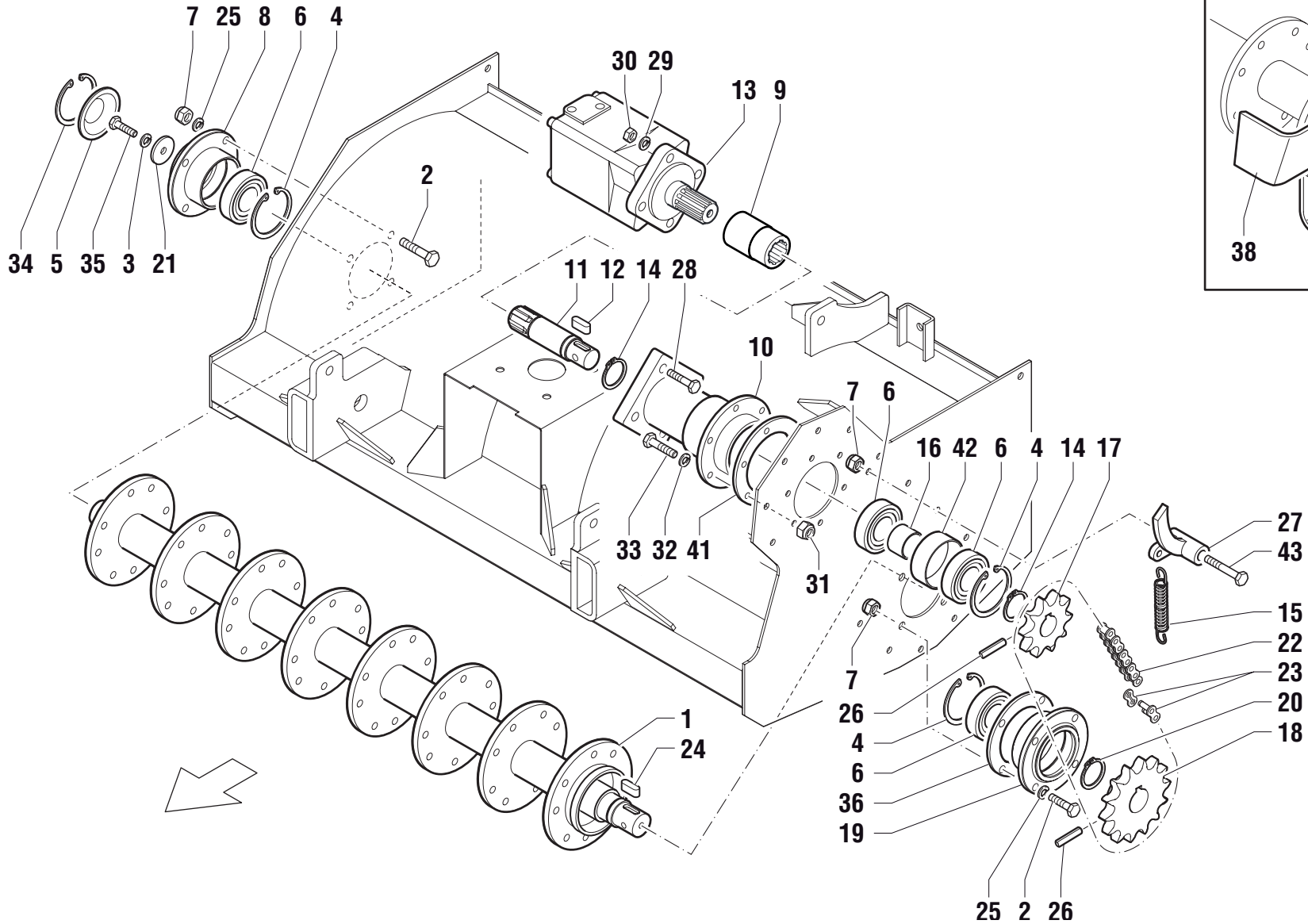

TST 100H

<i>Rif.</i>	<i>CODICE</i>	<i>Qty</i>	<i>Descrizione</i>	<i>Description</i>	<i>Designation</i>	<i>Benennung</i>	<i>Denominaciones</i>
1	060.003	1	ALBERO PORTACOLTELLI	CUTTER HOLDING SHAFT	ARBRE PORTE COUTEAUX	MESSERWELLE	ÁRBOL PORTRA CUCHILLAS
2	21.0.0.10030	8	VITE	SCREW	VIS	SCHRAUBE	TORNILLO
3	16.01.00.010	1	RONDELLA ELASTICA	SPRING WASHER	RONDELLE ELASTIQUE	FEDERSCHEIBE	ARANDELA ELASTICA
4	18.00.01.072	3	ANELLO ELASTICO	SNAP RING	ANNEAU RESSORT	SICHERUNGSRING	ANILLO ELASTICO
5	060.087	1	COPERCHIO	COVER	COUVERCLE	DECKEL	TAPA
6	A6207	4	CUSCINETTO	BEARING	PALIER	LAGERSCHALE	COJINETE
7	30.01.00.010	9	DADO AUTOBLOCCANTE	STOP NUT	ECROU DE SURETE	SPERRMUTTER	TUERCA AUTOTRABADORA
8	060.006	1	MOZZO PORTA ALBERO	SHAFT HUB	MOYEU ARBRE	WELLENNABE	CUBO EJE
9	015.012	1	MANICOTTO TRASMISSIONE	TRANSMISSION SLEEVE	MANCHON TRANSMISSION	TRANSMISSIONSROHR	MANGUITO TRANSMISIÓN
10	015.011	1	SUPPORTO	SUPPORT	SUPPORT	LAGER	SOPORTE
11	060.010	1	ALBERO DI TRASMISSIONE	PROPELLER SHAFT	ARBRE DE TRANSMISSION	WELLE TRANSMISSION	ARBOL DE TRANSMISIÓN
12	35.1.0.08030	1	LINGUETTA	KEY	CLAVETTE	KEIL	CHAVETA
13	050.045	1	MOTORE IDRAULICO	HYDRAULIC MOTOR	MOTEUR HYDRAULIQUE	HYDRAULIKMOTOR	MOTOR HIDRAULICO
14	18.01.00.035	2	ANELLO ELASTICO	SNAP RING	ANNEAU RESSORT	SICHERUNGSRING	ANILLO ELASTICO
15	050.117	1	MOLLA	SPRING	RESSORT	FEDER	RESORTE
16	031.045	1	DISTANZIALE	SPACER	ENTRETOISE	ABSTANDSTUECK	SEPARADOR
17	060.013	1	PIGNONE	PINION	PIGNON	RITZEL	PINON
18	060.014	1	CORONA	RING GEAR	COURONNE	KRANZ	CORONA
19	060.005	1	MOZZO PORTA ALBERO	SHAFT HUB	MOYEU ARBRE	WELLENNABE	CUBO EJE
20	18.01.00.040	1	ANELLO ELASTICO	SNAP RING	ANNEAU RESSORT	SICHERUNGSRING	ANILLO ELASTICO
21	15.1.0.01.010	1	RONDELLA	WASHER	RONDELLE	SCHEIBE	ARANDELA
22	050.105	1	CATENA	CHAIN	CHAÎNE	KETTE	CADENA
23	050.105/A	1	MAGLIA DI GIUNZIONE	CHAIN JOINT	JOINT DE CHAÎNE	STECKGLIED	UNIÓN DE CADENA
24	35.1.0.10030	1	LINGUETTA	KEY	CLAVETTE	KEIL	CHAVETA
25	16.01.01.010	16	RONDELLA ELASTICA	SPRING WASHER	RONDELLE ELASTIQUE	FEDERSCHEIBE	ARANDELA ELASTICA
26	38.1.1.10050	2	SPINA ELASTICA	SPLIT PIN	BROCHE ELASTIQUE	ZAPFEN FEDRIG	PERNO ELASTICO
27	060.016	1	TENDICATENA	CHAIN STRETCHER	TENDEUR DE CHAINE	KETTENSPIANN	TENJOR DE CADENA
28	22.0.1.12055	4	VITE	SCREW	VIS	SCHRAUBE	TORNILLO
29	16.01.01.012	4	GROWER	GROWER	GROWER	GROWER	GROWER
30	31.02.00.0.12	4	DADO	NUT	ECROU	MUTTER	TUERCA
31	30.03.00.008	6	DADO AUTOBLOCCANTE	STOP NUT	ECROU DE SURETE	SPERRMUTTER	TUERCA AUTOTRABADORA





TRASMISSIONE IDRAULICA
HYDRAULIC TRANSMISSION
TRANSMISSION HYDRAULIQUE
HYDRAULIKANTRIEB
TRANSMISIÓN HIDRÁULICA

Tav. 08.0

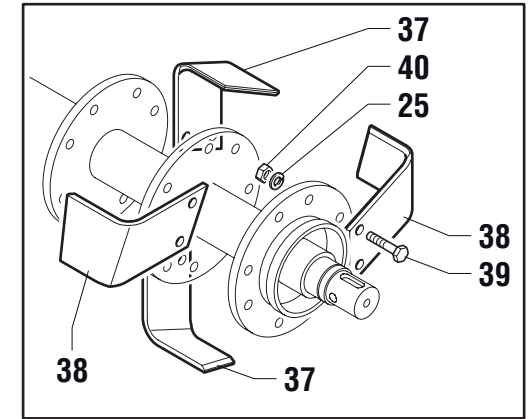
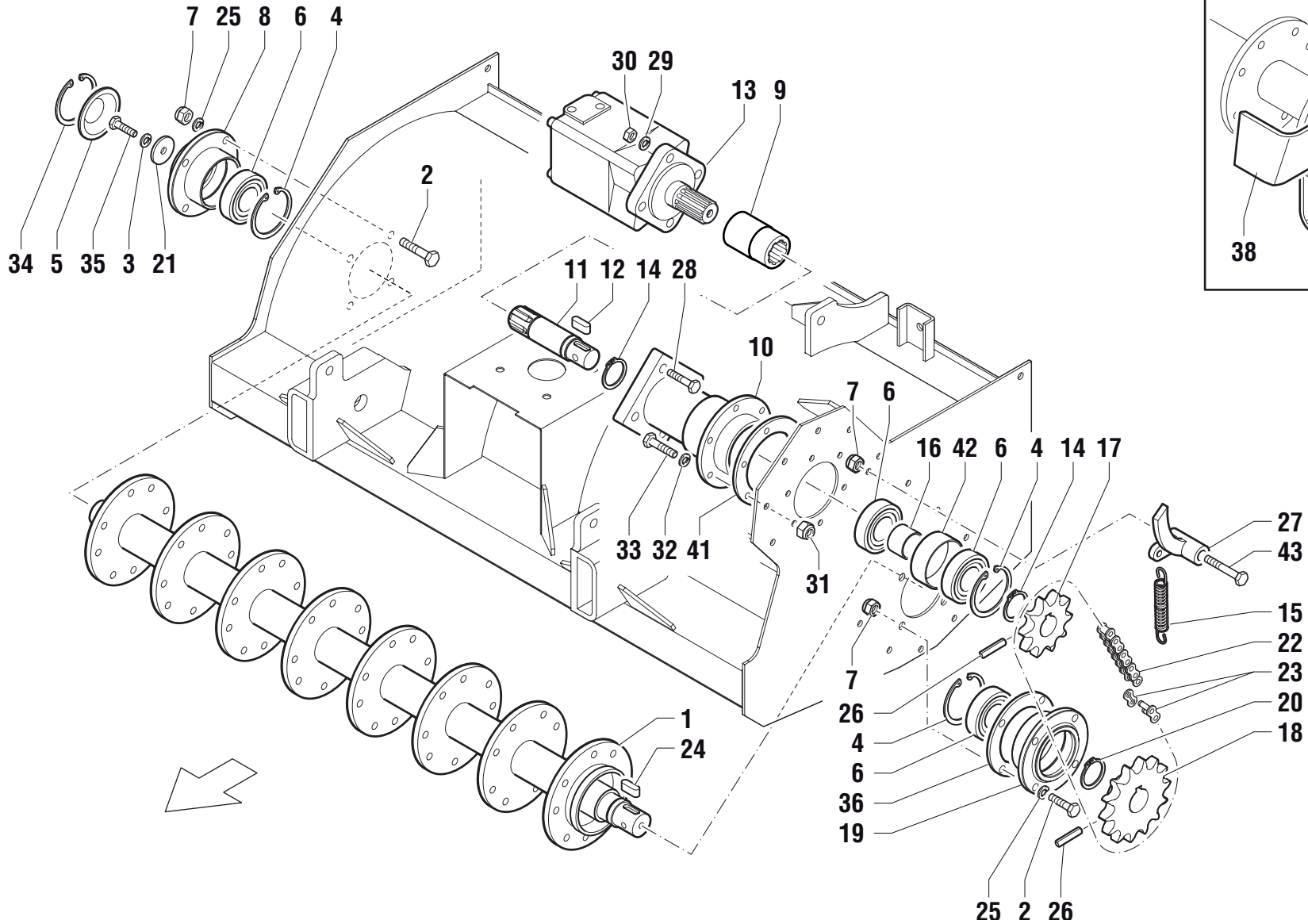

TST 100H



TRASMISSIONE IDRAULICA
HYDRAULIC TRANSMISSION
TRANSMISSION HYDRAULIQUE
HYDRAULIKANTRIEB
TRANSMISSION HIDRÁULICA

Tav. 09.0

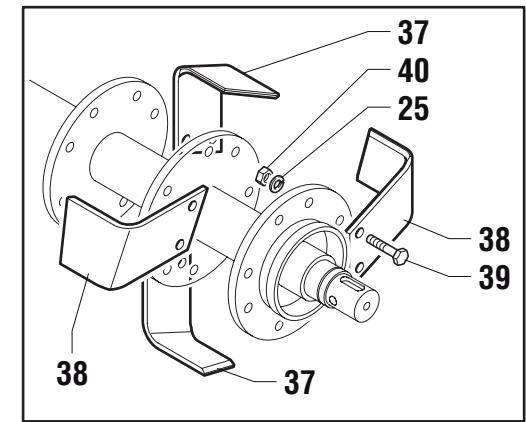
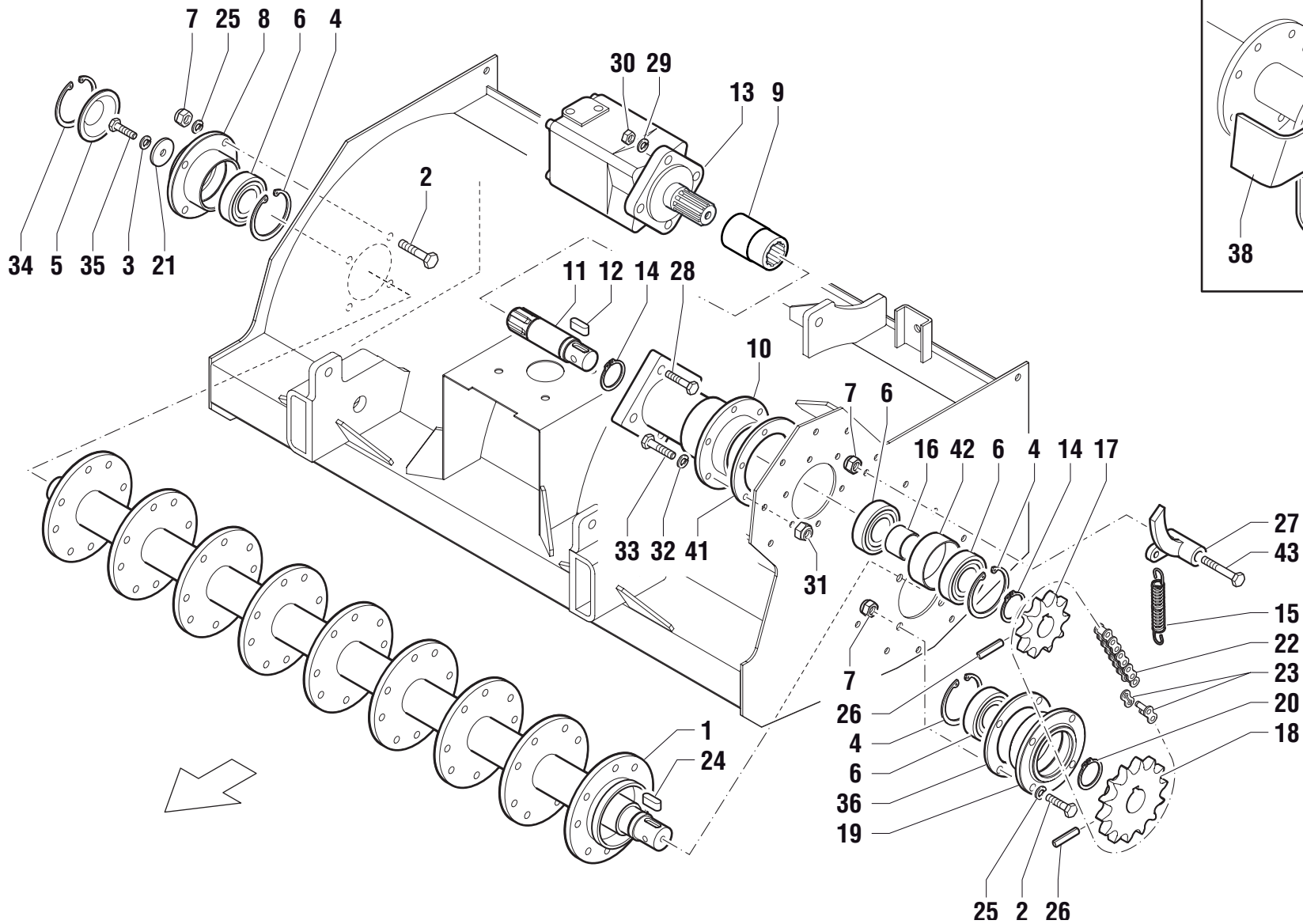

TST 113H

<i>Rif.</i>	<i>CODICE</i>	<i>Qty</i>	<i>Descrizione</i>	<i>Description</i>	<i>Designation</i>	<i>Benennung</i>	<i>Denominaciones</i>
1	060.047	1	ALBERO PORTACOLTELLI	CUTTER HOLDING SHAFT	ARBRE PORTE COUTEAUX	MESSERWELLE	ÁRBOL PORTRA CUCHILLAS
2	21.0.0.10030	8	VITE	SCREW	VIS	SCHRAUBE	TORNILLO
3	16.01.00.010	1	RONDELLA ELASTICA	SPRING WASHER	RONDELLE ELASTIQUE	FEDERSCHEIBE	ARANDELA ELASTICA
4	18.00.01.072	3	ANELLO ELASTICO	SNAP RING	ANNEAU RESSORT	SICHERUNGSRING	ANILLO ELASTICO
5	060.087	1	COPERCHIO	COVER	COUVERCLE	DECKEL	TAPA
6	A6207	4	CUSCINETTO	BEARING	PALIER	LAGERSCHALE	COJINETE
7	30.01.00.010	9	DADO AUTOBLOCCANTE	STOP NUT	ECROU DE SURETE	SPERRMUTTER	TUERCA AUTOTRABADORA
8	060.006	1	MOZZO PORTA ALBERO	SHAFT HUB	MOYEU ARBRE	WELLENNABE	CUBO EJE
9	015.012	1	MANICOTTO TRASMISSIONE	TRANSMISSION SLEEVE	MANCHON TRANSMISSION	TRANSMISSIONSROHR	MANGUITO TRANSMISIÓN
10	015.011	1	SUPPORTO	SUPPORT	SUPPORT	LAGER	SOPORTE
11	060.010	1	ALBERO DI TRASMISSIONE	PROPELLER SHAFT	ARBRE DE TRANSMISSION	WELLE TRANSMISSION	ARBOL DE TRANSMISIÓN
12	35.1.0.08030	1	LINGUETTA	KEY	CLAVETTE	KEIL	CHAVETA
13	050.045	1	MOTORE IDRAULICO	HYDRAULIC MOTOR	MOTEUR HYDRAULIQUE	HYDRAULIKMOTOR	MOTOR HIDRAULICO
14	18.01.00.035	2	ANELLO ELASTICO	SNAP RING	ANNEAU RESSORT	SICHERUNGSRING	ANILLO ELASTICO
15	050.117	1	MOLLA	SPRING	RESSORT	FEDER	RESORTE
16	031.045	1	DISTANZIALE	SPACER	ENTRETOISE	ABSTANDSTUECK	SEPARADOR
17	060.013	1	PIGNONE	PINION	PIGNON	RITZEL	PINON
18	060.014	1	CORONA	RING GEAR	COURONNE	KRANZ	CORONA
19	060.005	1	MOZZO PORTA ALBERO	SHAFT HUB	MOYEU ARBRE	WELLENNABE	CUBO EJE
20	18.01.00.040	1	ANELLO ELASTICO	SNAP RING	ANNEAU RESSORT	SICHERUNGSRING	ANILLO ELASTICO
21	15.1.0.01.010	1	RONDELLA	WASHER	RONDELLE	SCHEIBE	ARANDELA
22	050.105	1	CATENA	CHAIN	CHAÎNE	KETTE	CADENA
23	050.105/A	1	MAGLIA DI GIUNZIONE	CHAIN JOINT	JOINT DE CHAÎNE	STECKGLIED	UNIÓN DE CADENA
24	35.1.0.10030	1	LINGUETTA	KEY	CLAVETTE	KEIL	CHAVETA
25	16.01.01.010	16	RONDELLA ELASTICA	SPRING WASHER	RONDELLE ELASTIQUE	FEDERSCHEIBE	ARANDELA ELASTICA
26	38.1.1.10050	2	SPINA ELASTICA	SPLIT PIN	BROCHE ELASTIQUE	ZAPFEN FEDRIG	PERNO ELASTICO
27	060.016	1	TENDICATENA	CHAIN STRETCHER	TENDEUR DE CHAINE	KETTENSPIANN	TENJOR DE CADENA
28	22.0.1.12055	4	VITE	SCREW	VIS	SCHRAUBE	TORNILLO
29	16.01.01.012	4	GROWER	GROWER	GROWER	GROWER	GROWER
30	31.02.00.0.12	4	DADO	NUT	ECROU	MUTTER	TUERCA
31	30.03.00.008	1	DADO AUTOBLOCCANTE	STOP NUT	ECROU DE SURETE	SPERRMUTTER	TUERCA AUTOTRABADORA





TRASMISSIONE IDRAULICA
HYDRAULIC TRANSMISSION
TRANSMISSION HYDRAULIQUE
HYDRAULIKANTRIEB
TRANSMISSION HIDRÁULICA

Tav. 09.0

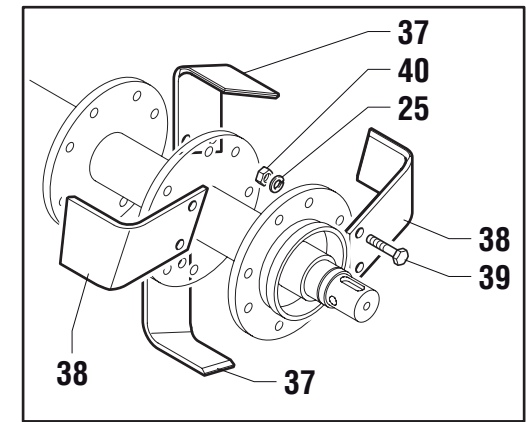
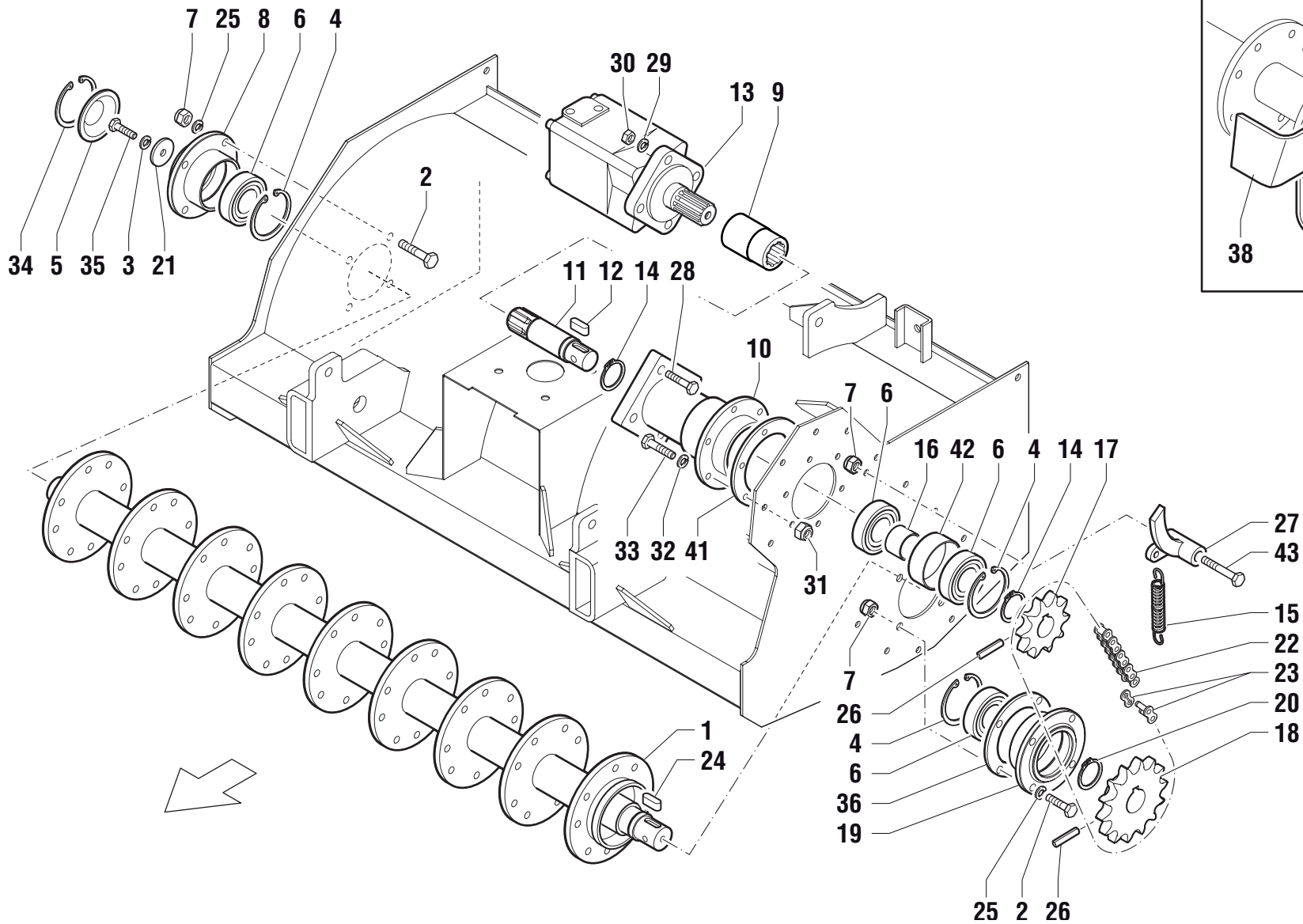

TST 113H



TRASMISSIONE IDRAULICA
HYDRAULIC TRANSMISSION
TRANSMISSION HYDRAULIQUE
HYDRAULIKANTRIEB
TRANSMISSION HIDRÁULICA

Tav. 10.0

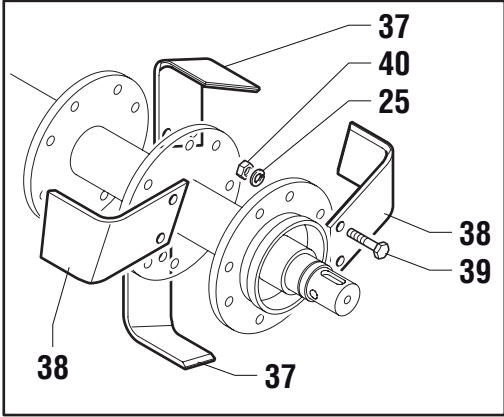
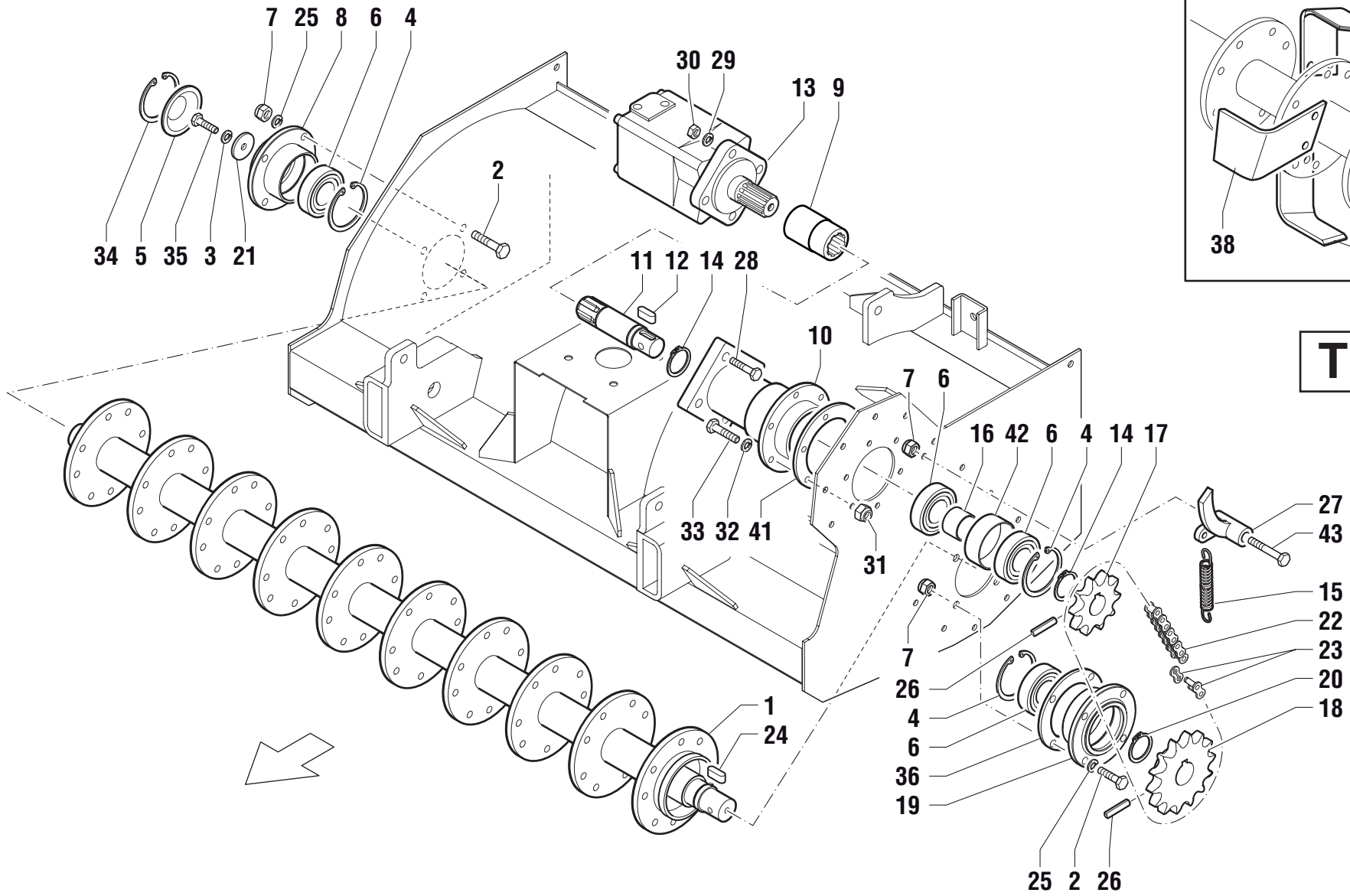

TST 130H

<i>Rif.</i>	<i>CODICE</i>	<i>Qty</i>	<i>Descrizione</i>	<i>Description</i>	<i>Designation</i>	<i>Benennung</i>	<i>Denominaciones</i>
1	060.044	1	ALBERO PORTACOLTELLI	CUTTER HOLDING SHAFT	ARBRE PORTE COUTEAUX	MESSERWELLE	ÁRBOL PORTA CUCHILLAS
2	21.0.0.10030	8	VITE	SCREW	VIS	SCHRAUBE	TORNILLO
3	16.01.00.010	1	RONDELLA ELASTICA	SPRING WASHER	RONDELLE ELASTIQUE	FEDERSCHEIBE	ARANDELA ELASTICA
4	18.00.01.072	3	ANELLO ELASTICO	SNAP RING	ANNEAU RESSORT	SICHERUNGSRING	ANILLO ELASTICO
5	060.087	1	COPERCHIO	COVER	COUVERCLE	DECKEL	TAPA
6	A6207	4	CUSCINETTO	BEARING	PALIER	LAGERSCHALE	COJINETE
7	30.01.00.010	9	DADO AUTOBLOCCANTE	STOP NUT	ECROU DE SURETE	SPERRMUTTER	TUERCA AUTOTRABADORA
8	060.006	1	MOZZO PORTA ALBERO	SHAFT HUB	MOYEU ARBRE	WELLENNABE	CUBO EJE
9	015.012	1	MANICOTTO TRASMISSIONE	TRANSMISSION SLEEVE	MANCHON TRANSMISSION	TRANSMISSIONSROHR	MANGUITO TRANSMISIÓN
10	015.011	1	SUPPORTO	SUPPORT	SUPPORT	LAGER	SOPORTE
11	060.010	1	ALBERO DI TRASMISSIONE	PROPELLER SHAFT	ARBRE DE TRANSMISSION	WELLE TRANSMISSION	ARBOL DE TRANSMISIÓN
12	35.1.0.08030	1	LINGUETTA	KEY	CLAVETTE	KEIL	CHAVETA
13	050.045	1	MOTORE IDRAULICO	HYDRAULIC MOTOR	MOTEUR HYDRAULIQUE	HYDRAULIKMOTOR	MOTOR HIDRAULICO
14	18.01.00.035	2	ANELLO ELASTICO	SNAP RING	ANNEAU RESSORT	SICHERUNGSRING	ANILLO ELASTICO
15	050.117	1	MOLLA	SPRING	RESSORT	FEDER	RESORTE
16	031.045	1	DISTANZIALE	SPACER	ENTRETOISE	ABSTANDSTUECK	SEPARADOR
17	060.013	1	PIGNONE	PINION	PIGNON	RITZEL	PINON
18	060.014	1	CORONA	RING GEAR	COURONNE	KRANZ	CORONA
19	060.005	1	MOZZO PORTA ALBERO	SHAFT HUB	MOYEU ARBRE	WELLENNABE	CUBO EJE
20	18.01.00.040	1	ANELLO ELASTICO	SNAP RING	ANNEAU RESSORT	SICHERUNGSRING	ANILLO ELASTICO
21	15.1.0.01.010	1	RONDELLA	WASHER	RONDELLE	SCHEIBE	ARANDELA
22	050.105	1	CATENA	CHAIN	CHAÎNE	KETTE	CADENA
23	050.105/A	1	MAGLIA DI GIUNZIONE	CHAIN JOINT	JOINT DE CHAÎNE	STECKGLIED	UNIÓN DE CADENA
24	35.1.0.10030	1	LINGUETTA	KEY	CLAVETTE	KEIL	CHAVETA
25	16.01.01.010	16	RONDELLA ELASTICA	SPRING WASHER	RONDELLE ELASTIQUE	FEDERSCHEIBE	ARANDELA ELASTICA
26	38.1.1.10050	2	SPINA ELASTICA	SPLIT PIN	BROCHE ELASTIQUE	ZAPFEN FEDRIG	PERNO ELASTICO
27	060.016	1	TENDICATENA	CHAIN STRETCHER	TENDEUR DE CHAINE	KETTENSPIANN	TENJOR DE CADENA
28	22.0.1.12055	4	VITE	SCREW	VIS	SCHRAUBE	TORNILLO
29	16.01.01.012	4	GROWER	GROWER	GROWER	GROWER	GROWER
30	31.02.00.0.12	4	DADO	NUT	ECROU	MUTTER	TUERCA
31	30.03.00.008	1	DADO AUTOBLOCCANTE	STOP NUT	ECROU DE SURETE	SPERRMUTTER	TUERCA AUTOTRABADORA





TRASMISSIONE IDRAULICA
HYDRAULIC TRANSMISSION
TRANSMISSION HYDRAULIQUE
HYDRAULIKANTRIEB
TRANSMISSION HIDRÁULICA

Tav. 10.0

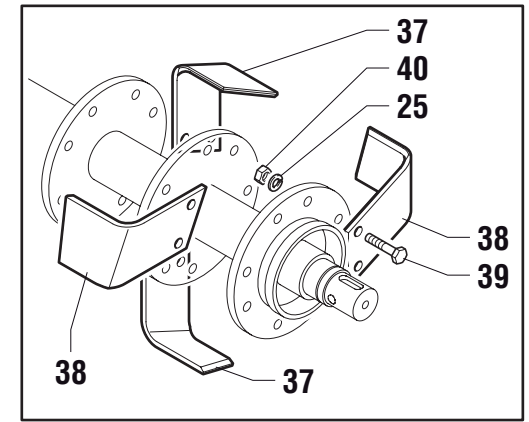
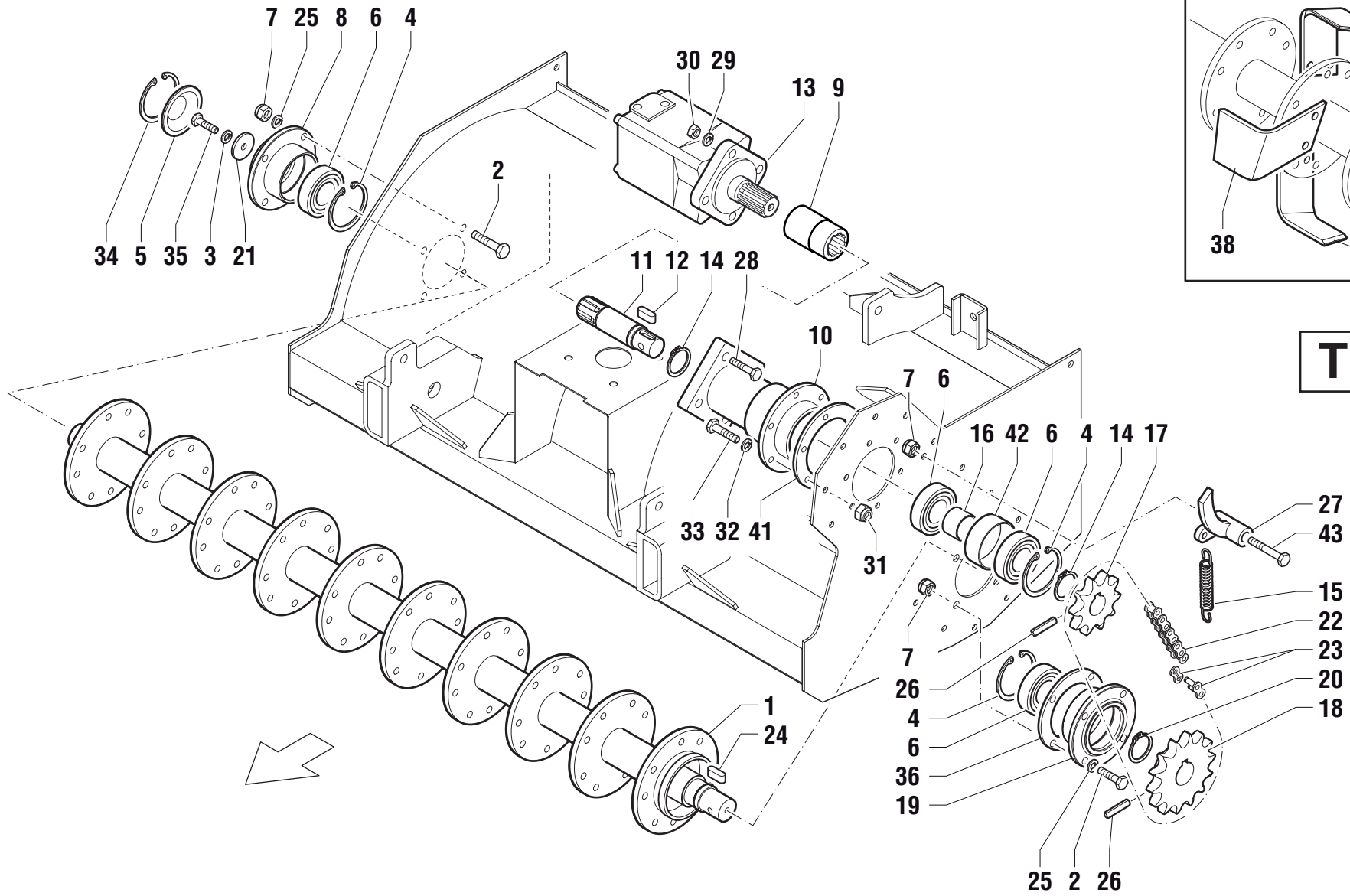

TST 130H

